

ChromaStar™

Infra-Red Radiant Heaters

- 1.5 to 13.5 kW
- 5,118 to 46,062 BTU/Hr
- 120, 208, 240, 277, 480, and 600 V
- Single or 3 Phase - Most Models Field Convertible
- Fixed Overhead - Convertible to Portable
- Portable/Factory Assembled
- Optional Accessories
 - Ground Fault
 - Disconnect
 - Tip Over Shut Down
- UL Listed, CSA Registered Models

Applications

- Localized heating in large plants
- Loading Docks
- Narrow warehouse aisle heating
- Garages
- Dry paint
- Prevent freezing of pipes, valves
- Heat hoppers

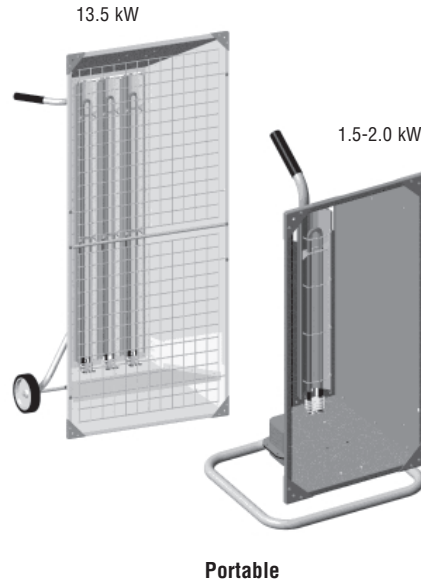

Description

The Chromalox ChromaStar™ infra-red comfort heaters are designed to provide a rugged source of heat for use in areas where dependence on air movement is impractical. The heaters are versatile, designed to provide warmth directly where it is needed for primary or spot heating applications. Each unit is constructed for long life and requires minimal maintenance. There are no moving parts or motors to wear out, no air filters or lubrication required.

All Chromalox ChromaStar™ radiant heaters feature the exclusive “Arctic End” Patent Pending heating element terminal construction. This feature lowers the terminal box temperatures resulting in extended element and wiring life.

Extruded aluminum housings are rigid to provide added protection to the heating elements located at the focal point of a built-in mirrored aluminum reflector(s).

The heater(s) consist of hairpin bent .430” diameter alloy sheath tubular element(s) constructed of high quality resistance wire embedded in carefully selected MgO refractory insulation. The element feature “Arctic end” terminal construction for longer life and cooler terminal enclosure temperatures. The element(s) also feature terminal construction using a waged-in silicone bushings that produce unequalled resistance to moisture absorption. The heating element(s) connect to a gasketed, moisture resistance terminal enclosure with liquid-tight bulkhead threaded fittings. An extension reflector constructed of 0.050” mirrored aluminum extends over the assembly to provide a more uniform heating pattern.

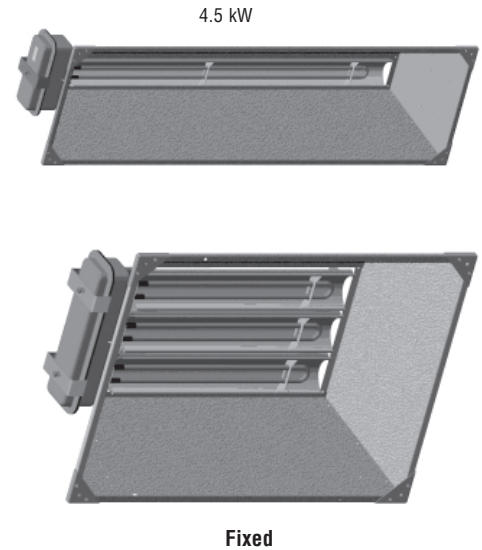

Portable

All portable heaters are supplied fully assembled to a rugged, chrome-nickel plated tubular steel cart and handle (1.5 and 2.0 kW heater has a fixed pedestal). The cart features large wheels for easy portability. All portable heaters include safety grills to protect personnel from contacting hot elements.

Field wiring is accomplished through a 3/4” conduit opening in terminal enclosure. The 1.5 kW unit comes complete with a factory installed 6 foot cord and 2 prong grounding type plug. Other models can be field wired using accessory cable and plug kits shown.

Fixed Overhead

The Chromalox ChromaStar™ radiant heater is shipped fully assembled and can be hung from the ceiling with 2 chains or rigid angle brackets attached to the heater brackets located on the back of the heater.

Field wiring is accomplished through the liquid tight terminal enclosure. No secondary splice box required.

Protective screens, disconnect switches and portable carts are available for these heaters as shown.

ChromaStar™

Infra-Red Radiant Heaters (cont'd.)

Fixed Overhead Radiant Heaters 2.0 to 4.5 kW Dimensions

U.L. Listed & CSA Certified for Fixed Installations

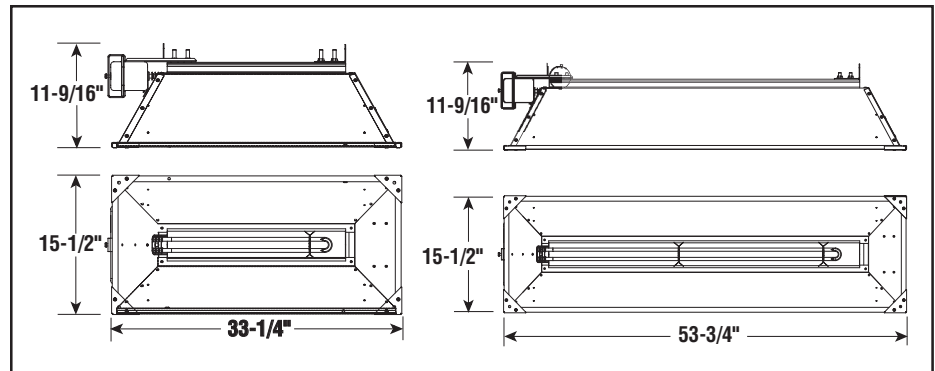

Specifications and Ordering Information

| Electrical | | | | | Dimensions (in.) | | | Ordering | | | |
|------------|-------|-------|------|--------|------------------|------------|------------|--------------|-------|--------|------------|
| kW | Volts | Phase | Amps | Btuh | Height | Base Width | Base Depth | Model | Stock | PCN | Wt. (Lbs.) |
| 2 | 208 | 1 | 9.6 | 6,824 | 33-1/4 | 15-1/2 | 11-9/16 | STAR-02-81-F | AS | 340558 | 14 |
| 2 | 240 | 1 | 8.3 | 6,824 | 33-1/4 | 15-1/2 | 11-9/16 | STAR-02-21-F | ST | 340566 | 14 |
| 2 | 277 | 1 | 7.2 | 6,824 | 33-1/4 | 15-1/2 | 11-9/16 | STAR-02-71-F | AS | 340574 | 14 |
| 2 | 480 | 1 | 4.2 | 6,824 | 33-1/4 | 15-1/2 | 11-9/16 | STAR-02-41-F | ST | 340582 | 14 |
| 2 | 600 | 1 | 3.3 | 6,824 | 33-1/4 | 15-1/2 | 11-9/16 | STAR-02-61-F | AS | 340590 | 14 |
| 4.5 | 208 | 1 | 21.6 | 15,354 | 53-3/4 | 15-1/2 | 11-9/16 | STAR-05-81-F | AS | 340435 | 23 |
| 4.5 | 240 | 1 | 18.8 | 15,354 | 53-3/4 | 15-1/2 | 11-9/16 | STAR-05-21-F | ST | 340443 | 23 |
| 4.2 | 277 | 1 | 16.2 | 15,354 | 53-3/4 | 15-1/2 | 11-9/16 | STAR-05-71-F | AS | 340451 | 23 |
| 4.5 | 480 | 1 | 9.4 | 15,354 | 53-3/4 | 15-1/2 | 11-9/16 | STAR-05-41-F | ST | 340460 | 23 |
| 4.5 | 600 | 1 | 7.5 | 15,354 | 53-3/4 | 15-1/2 | 11-9/16 | STAR-05-61-F | AS | 340478 | 23 |

Fixed Overhead Radiant Heaters 6.0 to 13.5 kW Dimensions

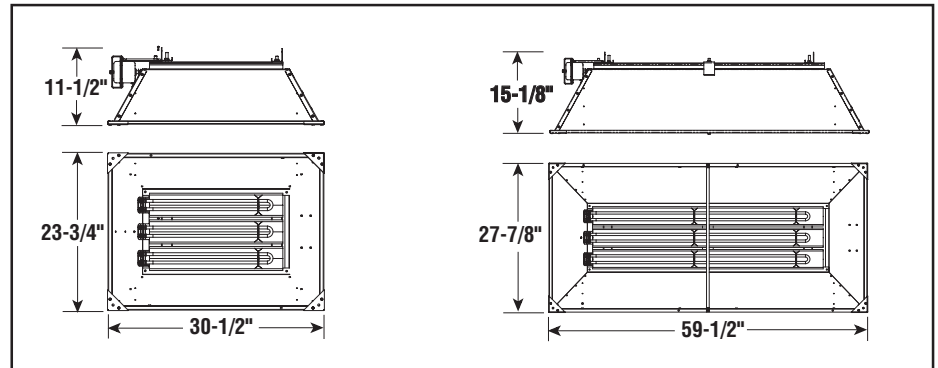

Specifications and Ordering Information

| Electrical | | | | | Dimensions (in.) | | | Ordering | | | |
|------------|-------|-------|------|--------|------------------|------------|------------|--------------|-------|--------|------------|
| kW | Volts | Phase | Amps | Btuh | Height | Base Width | Base Depth | Model | Stock | PCN | Wt. (Lbs.) |
| 6 | 208 | 3 | 16.7 | 20,472 | 30-1/2 | 23-3/4 | 11-1/2 | STAR-06-83-F | S | 340339 | 26 |
| 6 | 240 | 3 | 14.4 | 20,472 | 30-1/2 | 23-3/4 | 11-1/2 | STAR-06-23-F | S | 340347 | 26 |
| 6 | 277 | 1 | 21.7 | 20,472 | 30-1/2 | 23-3/4 | 11-1/2 | STAR-06-71-F | NS | 340355 | 26 |
| 6 | 480 | 3 | 7.2 | 20,472 | 30-1/2 | 23-3/4 | 11-1/2 | STAR-06-43-F | S | 340363 | 26 |
| 6 | 600 | 3 | 5.8 | 20,472 | 30-1/2 | 23-3/4 | 11-1/2 | STAR-06-63-F | NS | 340371 | 26 |
| 13.5 | 208 | 3 | 37.5 | 46,062 | 59-1/2 | 27-7/8 | 15-1/8 | STAR-14-83-F | S | 340232 | 44 |
| 13.5 | 240 | 3 | 32.5 | 46,062 | 59-1/2 | 27-7/8 | 15-1/8 | STAR-14-23-F | S | 340240 | 44 |
| 13.5 | 277 | 1 | 48.7 | 46,062 | 59-1/2 | 27-7/8 | 15-1/8 | STAR-14-71-F | NS | 340259 | 44 |
| 13.5 | 480 | 3 | 16.3 | 46,062 | 59-1/2 | 27-7/8 | 15-1/8 | STAR-14-43-F | S | 340267 | 44 |
| 13.5 | 600 | 3 | 13 | 46,062 | 59-1/2 | 27-7/8 | 15-1/8 | STAR-14-63-F | NS | 340275 | 44 |