

Series 5300

B/W ControlsTM

Intrinsically Safe Relays

Intrinsically safe control circuit approved by Factory Mutual for Class I, II, III; Division 1; Groups A, B, C, D, E, F, G hazardous locations.

BASIC SPECIFICATIONS

Dual Voltage: 115 or 230 VAC, +10%-20% — 50/60 Hz.

Load Contacts: Double pole, double throw.

Power Required: 9 volt-amperes, 6 watts.

Control Circuit Energy: Inherently limited to less than 1 milliamperes at 9.6 volts dc. to assure intrinsically safe operation under any abnormal fault condition.

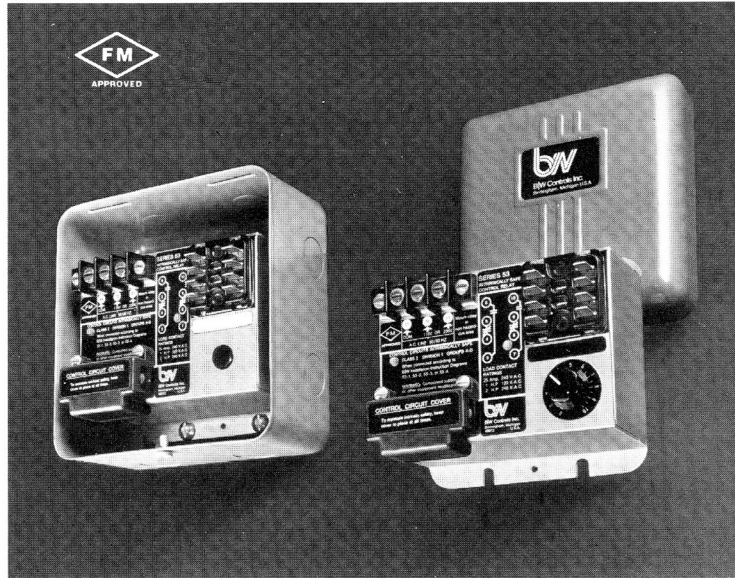

INTRINSIC SAFETY FOR CONTROLLING PROCESS FUNCTIONS IN HAZARDOUS AREAS

BIW Series 5300 Control Relays were developed especially to provide an intrinsically safe and economical means of detecting and controlling a wide range of processing variables in areas containing explosive atmospheric mixtures.

Tested and approved by Factory Mutual for use in applications involving Class I, II, and III locations, these compact solid-state relays are designed to provide an external probe or pilot control circuit that is inherently incapable of releasing sufficient electrical energy to ignite even the most flammable gases or vapors classified in Groups A, B, C, and D, and combustible dusts or fibers classified in Groups E, F, and G.

Typical Applications—Conditions covered by the above approvals include all the hazardous atmospheric mixtures encountered in refineries, chemical processing operations, manufacturing plants—mines, coal preparation and storage bins—hospitals, distilleries, grain elevators, feed and textile mills—industrial and municipal waste disposal systems—marine bilge and sewage treatment facilities — to mention just a few of the many areas for safe, practical installation.

Installation Options—When mounted in an approved explosion-proof enclosure, BIW Series 5300 Relays can be located within a hazardous area, providing the power wiring to the relay and from the load contacts is installed in accordance with applicable codes for the location. The most economical method of installation, however, is to mount the relay in a non-hazardous environment and run the external control circuit through an approved seal to a pilot device or

level sensing electrodes in the hazardous area.

This permits use of low-cost general purpose enclosures for both the relay and pilot device. Ordinary wires in conduit or an approved cable can be used for the intrinsically safe probe or pilot control circuit. Moreover, distance between the Series 5300 Relay and the pilot device can be 10,000 feet or more, depending on resistance and capacitance of the wires used for the external control circuit.

Relay Types and Options—BIW Series 5300 Relays can be supplied with either Standard or Power load contacts, and equipped with variable resistance potentiometer or choice of fixed resistors to meet the operating requirements of countless level sensing and pilot switching control applications.

Standard load contacts are more than adequate for most applications and, in fact, assure greater reliability where light loads and low voltages and currents are involved. The higher rated Power contacts are available to handle heavy-duty loads, but are not recommended for use at less than 10% of their specified ratings.

Operating sensitivity is important only in level control applications where the relay is operated from electrodes and the liquid is used as a conductor to complete the external sensing circuit. Since liquid resistances vary, several operating sensitivities are offered. In such applications, the relay must have a sensitivity greater than the specific resistance of the liquid being controlled. When operated from a BIW Unifloat® multi-level sensing system or other pilot switching device, a fixed 10,000 ohm sensitivity is recommended.

Regardless of sensitivity ratings, however, all BIW Series 5300 Relays are designed to operate continuously with external probe or pilot circuit resistances as low as zero without damaging the relay. This permits intrinsically safe operation at all times from electrodes or pilot switches.



Intrinsically safe control circuit approved by Factory Mutual for Class I, II, III; Division 1 Groups A, B, C, D, E, F, and G hazardous locations.

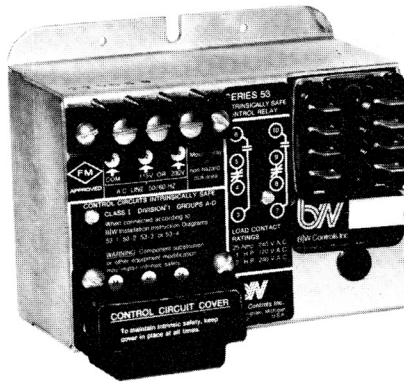

Series 5300 Intrinsically Safe Control Relay with fixed sensitivity resistor

5300 — P

CATALOG SECTION

CONTACT TYPE

P	Power Contacts* 25 Amp Resistive at 120 or 240 V.A.C.
----------	---

* Power contacts not recommended for use on less than 2.5 ampere load.

BIW PART NUMBER CROSS REFERENCE

OLD PART NO.	NEW CAT. NO.
53-1200	5300-P-V*
53-1201	5300-P-F1*
53-1202	5300-P-F2*
53-1203	5300-P-F3*
53-1204	5300-P-F4*
53-1205	5300-P-F5*
53-1206	5300-P-F6*
53-1207	5300-P-F7*
53-1208	5300-P-F8*
	5300-S-V*
See Catalog Numbering System For Completion of Catalog Number	

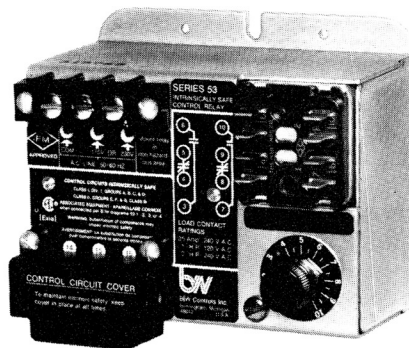

Series 5300 Intrinsically Safe Control Relay with variable sensitivity potentiometer

SERIES 5300 RELAY CHASSIS DIMENSIONS

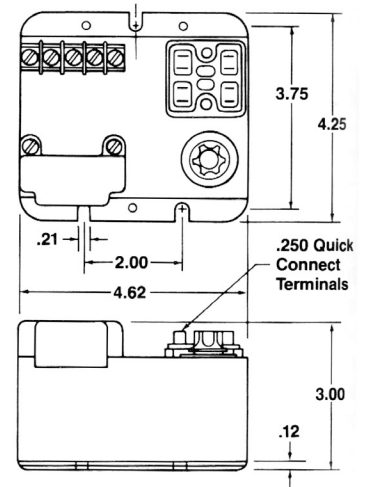

Series 5300
B/W Controls™
Intrinsically Safe Relays

SERIES 5300 CATALOG NUMBERING SYSTEM

V	Operating Sensitivity Maximum Control Circuit Resistance	Maximum Lead Wire Lengths	Application Recommendations	OC	ENCLOSURE TYPE
V	Variable 10,000 ohms to 1 megohm	Same as F1 — F5	Covers all applications described for F1 — F5	OC	Open Chassis
F1	Fixed, 10,000 ohms	50,000 ft.	Unifloat® and other dry contacts, ordinary water with medium to high mineral content, sewage, water soluble oil and starch solutions, long distance applications	N1	Nema 1 General Purpose
F2	Fixed, 22,000 ohms	50,000 ft.	Water with low mineral content (soft — not distilled or demineralized), sugar syrup solutions, long distance applications	N4	Nema 4 Water Tight
F3	Fixed, 68,000 ohms	50,000 ft.	Steam condensate, corn syrup, strong alcohol solutions up to 50%	N7	Explosion Proof*
F4	Fixed, 330,000 ohms	50,000 ft.	Alcohol solutions up to 70%	N12	Nema 12 Oil Tight
F5	Fixed, 820,000 ohms	35,000 ft.	Deionized or distilled water, 95% glycerine, 90% hydrogen peroxide, 95% ethyl alcohol, granular solids with high moisture content		
F6	Fixed, 2.2 megohms	12,000 ft.	Glacial acetic acid, acetone, granular solids with some moisture content		
F7	Fixed, 5.6 megohms	4,000 ft.	M.E.K. (Methyl ethyl keytone)		
F8	Fixed, 12.0 megohms	2,000 ft.	Anhydrous ammonia		

*N7 enclosure rated Class I, Group C, D
 Class II, Group E, F, G

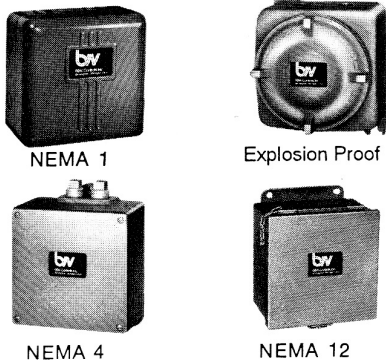

See page 12 for enclosure dimensions.

Note: DI water glycols, alcohols and granular solids may require the 2.2, 5.6 or 12.0 megohm R1 resistor depending upon their purity or moisture content.

INTRINSICALLY SAFE SYSTEM INSTALLATION

As defined by the National Electrical Code, Factory Mutual and Underwriters Laboratories, an intrinsically safe control system consists of equipment and associated wiring that are inherently incapable of releasing sufficient electrical or thermal energy under normal or abnormal conditions to cause ignition of a specific hazardous atmospheric mixture at its most easily ignited concentration in air.

Abnormal conditions would include any two independent mechanical or electrical faults occurring simultaneously — such as accidental damage to any part of the equipment, wiring and insulation, and any other failure of electrical components due to application of over-voltage, improper adjustment or maintenance, and other similar conditions.

When properly installed in accordance with the diagrams at right, BIW Series 5300 Relays meet the most stringent requirements of Factory Mutual for intrinsically safe operation from push-buttons, pressure or float switches, thermostats, humidistats or any other type of general purpose pilot control device. In addition, they may also be actuated by probes or electrodes in contact with any conductive liquid or moist bulk material to perform a wide variety of mixing, measuring, metering and flow or level control functions.

In such installations, inexpensive general purpose enclosures may be used for both the control relay and the pilot device—and wiring between the two may be of any type approved for non-hazardous locations without violating provisions of Article 500-517 of the National Electrical Code. It is essential, however, that

- (1) an approved seal be used at the point where the intrinsically safe pilot control circuit enters the hazardous area, and
- (2) the pilot circuit wiring be isolated from other wiring.

SINGLE SWITCH OPERATION Fixed Sensitivity Control

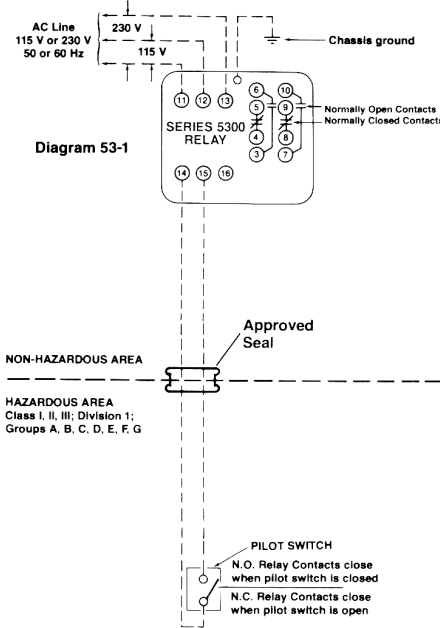

TWO SWITCH OPERATION Fixed Sensitivity Control

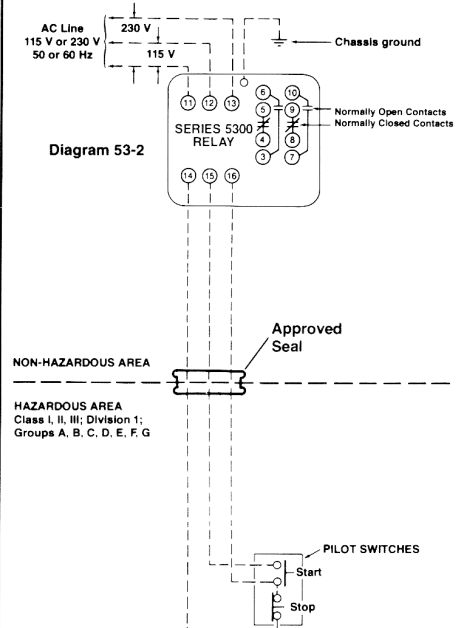

SINGLE LEVEL OPERATING Fixed or Adjustable Sensitivity Control

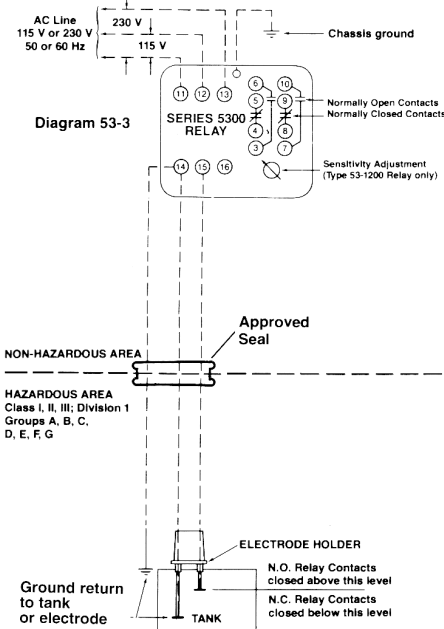

TWO LEVEL OPERATION Fixed or Adjustable Sensitivity Control

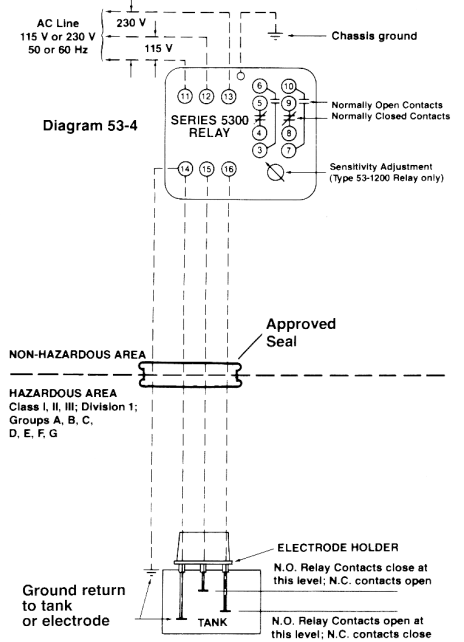

INTRINSICALLY SAFE REMOTE CONTROL WITH SERIES 5300 CONTROL RELAY OPERATING FROM CONTACTS OF A PILOT SWITCH

