

## PFC-B

### Hot Oil System

- Heat Transfer Fluids<sup>1</sup> to 600°F
- 9 - 600 kW (31 - 2,047 Mbh)<sup>2</sup>
- 240 and 480V, 3 Phase, 60 Hz<sup>3</sup>
- Non-Pressurized (Atmospheric) Operation
- 150 Lb Carbon Steel Construction
- Long Life 0.475" Dia. Steel Sheath Elements
- High Temperature Centrifugal Pump with Labyrinth Seal Ring — Requires No External Cooling up to 600°F
- Bypass Relief Line Protects System in Case of Blocked Flow
- Electronic Digital Temperature and Process Control
- Suction and Discharge Pressure Gauges Monitor Pump Performance
- NEMA 1 Electrical Enclosure Complete with Circuit Breaker, Contactors, Fusing, Switches, Transformers and Pilot Lights
- External Cold Expansion Tank (Optional) with Atmospheric Vent

**WARNING** — In hazardous areas, pipe surfaces could achieve temperatures high enough to cause auto-ignition of the hazardous materials present. Consult Article 500 of the National Electrical Code for further information on the maximum allowable temperatures for a specific application.



#### Applications

Chromalox PFC Hot Oil Heat Transfer Systems are engineered to operate up to 600°F at atmospheric pressure (non-pressurized). They are used with Mobiltherm®, Ucon®, Caloria® and other medium temperature heat transfer fluids<sup>1</sup> which do not require pressurization to operate at temperature.

PFC systems use a cold expansion tank (optional) that is open to the atmosphere. A cold expansion tank eliminates the need for nitrogen (N<sub>2</sub>) purging and reduces the tendency of the heat transfer fluid to oxidize and deteriorate.

#### Construction

PFC systems are ruggedly constructed and completely self contained (except for the optional external expansion tank). They are similar to the COS system except they use a high temperature centrifugal pump instead of a positive displacement pump. The centrifugal pump has a labyrinth seal ring which does not require cooling up to its maximum operating temperature of 600°F. PFC systems come complete with heaters, controls, pumps, valves, safety devices and necessary plumbing. Systems are factory tested and ready to operate.

#### Specifications and Ordering Information

kW	Pump Rate <sup>A</sup> (GPM)	Pump Motor (HP)	Inlet/Outlet Pipe Size 150 Lb Flg	Dimensions (In.)							
				L	D	H	A	B	C	E	G
9-30	40	3	1-1/2	54	35	77	24	12	36	6	50
40	60	5	2	54	40	77	24	12	36	6	50
60	80	5	2	54	40	81	24	11-1/4	36	5-1/2	50
80	80	5	2	54	40	96	35	11-1/4	45	5-1/2	66
100	120	7-1/2	3	54	40	96	36	13-1/2	48	6-1/2	66
125-150	150	7-1/2	3	60	45	96	45	12	54	8	66
200	150	7-1/2	3	60	45	96	45	12	57	8	66
250-400	200	10	3	62	60	96	42	22	54	12	66
450-600	350	15	4	84	60	96	45	22	57	12	66

A. Pumping rate based on 100 ft. total discharge head (TDH) using heat transfer fluid with a viscosity of approximately 100 SSU @ 70°F.

#### Other Notes —

1. For a list of compatible heat transfer fluids, contact your Local Chromalox Sales office.
2. kW ratings above 600 (to 1,200 kW) available.
3. Other voltages to 575V available.

## PFC-B

### Hot Oil System (cont'd.)

#### Features

- Overtemperature Cutout** protects elements and fluid from overheating
- Electrical Interlock** between pump motor and heating element contactors
- Flexible Piping** before and after pump absorbs vibration and prevents pump damage from thermal expansion
- Inline 0.030 Mesh Strainer** protects pump
- Full Port Manual Gate Valves** on all primary hydraulic piping minimizes pressure drop
- 2 Inch Thermal Insulation** around heating chambers minimizes heat loss
- 16 Gauge Painted Steel Panels** on all exposed sides — powder coat heat resistant paint

#### Options

- Alternate Voltage and kW Ratings
- Microprocessor based PID or Ramp Soak Temperature Controls
- Electronic Solid State (SCR) Power Controllers
- Electronic Sequencers, Recorders, Monitors, Time Clocks and Digital Communication Interface available
- Mechanical Pump Seals and Special Pumps
- Type RJC Closed-loop Cooling Modules
- Expansion Tanks Matched to System (recommended)
- Float or Level Switches for Expansion Tank
- ASME Section VIII Certification 100 psi at 600°F

#### Electrical Enclosure Options

- NEMA 1 enclosures and open drip proof motors are standard on all Chromalox hot oil systems. All systems (except OTCS) available with optional enclosures that comply with:
  - NEMA 4/12 Weather Resistant/Oil and Dust Tight with TEFC motors
  - Explosion Resistant Class I, Group D, Div. 1 with TEFC Explosion Resistant motors.

#### Dimensions (Inches)

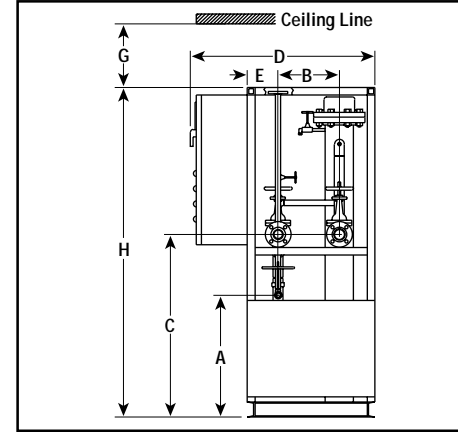
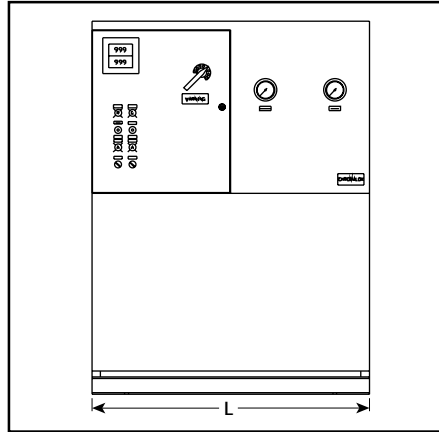

#### Specifications and Ordering Information

kW	Volts	Btuh	Min. Rec. Expansion Tank (Gal.) <sup>1</sup>	System Volume (Gal.)	No. Heating Stages	Model <sup>2</sup>	Stock	PCN	Wt. (Lbs.)
9	240	30,708	12	4	1	PFC-600B-9	NS	—	1,000
9	480	30,708	12	4	1	PFC-600B-9	NS	—	1,000
12	240	40,944	12	7	1	PFC-600B-12	NS	—	1,100
12	480	40,944	12	7	1	PFC-600B-12	NS	—	1,100
15	240	51,180	18	7	1	PFC-600B-15	NS	—	1,100
15	480	51,180	18	7	1	PFC-600B-15	NS	—	1,100
20	240	68,240	18	7	1	PFC-600B-20	NS	—	1,200
20	480	68,240	18	7	1	PFC-600B-20	NS	—	1,200
30	240	102,360	18	7	1	PFC-600B-30	NS	—	1,300
30	480	102,360	18	7	1	PFC-600B-30	NS	—	1,300
40	240	136,480	30	10	2	PFC-600B-40	NS	—	1,400
40	480	136,480	30	10	2	PFC-600B-40	NS	—	1,400
60	240	204,720	42	16	3	PFC-600B-60	NS	—	1,700
60	480	204,720	42	16	3	PFC-600B-60	NS	—	1,700
80	240	272,960	42	20	3	PFC-600B-80	NS	—	1,800
80	480	272,960	42	20	3	PFC-600B-80	NS	—	1,800
100	240	341,200	80	30	4	PFC-600B-100	NS	—	1,900
100	480	341,200	80	30	4	PFC-600B-100	NS	—	1,900
125	480	426,450	80	42	4	PFC-600B-125	NS	—	2,000
150	480	511,811	80	42	4	PFC-600B-150	NS	—	2,000
200	480	682,400	80	55	4	PFC-600B-200	NS	—	2,100
250	480	852,900	115	76	6	PFC-600B-250	NS	—	3,100
300	480	1,023,600	115	76	6	PFC-600B-300	NS	—	3,200
350	480	1,194,200	115	100	6	PFC-600B-350	NS	—	3,400
400	480	1,364,800	115	100	6	PFC-600B-400	NS	—	3,500
450	480	1,535,400	215	110	6	PFC-600B-450	NS	—	4,500
500	480	1,706,000	215	145	9	PFC-600B-500	NS	—	4,700
600	480	2,047,200	215	145	9	PFC-600B-600	NS	—	5,000

**Stock Status:** S = stock AS = assembly stock NS = non-stock  
**To Order**—Specify model, volts, phase, kW, PCN, options and quantity.

1. Expansion tank size should be double the increase in volume due to thermal expansion of heat transfer fluid.
2. Does not include expansion tank; see System Options for details.