



CSSB-A

Stainless Steel Vertical Steam Boiler

- Steam Pressures to 90 psig
- Steam Capacity (18 - 542 Lbs/Hr @ 0 - 90 psig)
- 6 - 180 kW (21 - 614 Mbh)
- 208, 240 and 480 Volt, 1 & 3 Phase
- ASME Section I Pressure Vessel Stainless Steel Code "M" (100 psig)
- 0.430 Dia. INCOLOY® Sheath Heating Elements
- One or Two Operating Controls Manual Reset High Limit
- Float Water Feed Control with Low Water Cutoff
- Pressure Gauge, Water Level Sight Glass and Blow Down Drain Valve(s)
- ASME Safety Relief Valve

Applications

CSSB All Stainless Steel Steam Boilers are specifically designed for use where the purity of the heating fluid must be maintained. Typical applications include sterilizers and autoclaves in research, biological and pharmaceutical laboratories and humidification equipment for the electronics industry (solid state substrates).

CSSB boilers utilize de-ionized, demineralized or distilled water to provide pure steam, free of minerals or undesirable chemical additives. Pure steam eliminates the possibility of carry over of contaminants into the process.

Note — A water feed system supplying distilled, de-ionized or demineralized water is required on all CSSB boilers. (See Caution note.)



Features

Stainless Steel Construction — Pressure vessel and all wetted parts are made of 304 stainless steel for operation with pure water. Type 316 stainless steel construction is available.

Low Water Cutoff and Level Control — Float type constructed of stainless steel automatically maintains correct water level in the boiler and shuts down the boiler if the level drops below safe operating limits.

Operating Controls — All stainless steel pressure controls provide accurate regulation of steam pressure.

High Pressure Limit Control — All stainless steel manual reset pressure limit control shuts down boiler if operating pressure exceeds set point.

Water Level Sight Glass — Furnished with stainless steel valves, provides for constant visual observation of the water level in the boiler.

Pressure Gauge, Safety Valve, Drain and Blow Down Valves are constructed of stainless steel for compatibility with basic boiler.

CSSB Steam Boilers are Trimmed at 100 psig for operation to 90 psig and come complete, factory tested and ready to operate. Boilers are available (on order) with 15, 30 and 50 psig. All catalog CSSB boilers are UL Listed.

Optional Equipment

All optional equipment (except blow down separator) is available in stainless steel construction for compatibility with the basic boiler.

Auxiliary Low Water Cutoff uses vertical ball float with electronic control. This option is required by some state or local boiler codes.

Proportional Control with electronic solid state sequencer for modulated pressure control.

Low or High Pressure Water Feed System (Required) for mounting on boiler or remote installation.

Heavy Duty Vacuum Breaker prevents siphoning of condensate from condensate return systems.

Automatic Blow Down System eliminates need for daily manual blow-down maintenance.

Blow Down Separator for blow down of a boiler where steam and hot water cannot be discharged directly into a drain. Blow down separator uses city water for cooling.

CAUTION — The use of chlorinated or regular tap water in stainless steel boilers is specifically prohibited by the ASME Code. The feed water for CSSB boilers must be distilled, de-ionized or demineralized water with a minimum specific resistivity of 1 megohm/cm. Failure to use the correct type of water will damage the equipment and void the factory warranty.

CSSB-A

Stainless Steel Vertical Steam Boiler (cont'd.)

Specifications and Ordering Information

Steam ¹ Lbs/Hr	Bhp	kW	Volts ²	Ph	3 Ph ² Amps	Service ⁴ Wire Size	DIM (In.)			Model	Stock	PCN	Wt. (Lbs.)
							W	L ⁵	H				
CSSB-A with One Operating Pressure Control³ (Transformer Optional)													
18.1	0.61	6	208	3	17	12	23	31	37	CSSB-006A	NS	—	230
18.1	0.61	6	240	3	15	12	23	31	37	CSSB-006A	NS	—	230
18.1	0.61	6	480	3	8	12	23	31	37	CSSB-006A	NS	—	230
27.1	0.92	9	208	3	25	10	23	31	37	CSSB-009A	NS	—	235
27.1	0.92	9	240	3	22	10	23	31	37	CSSB-009A	NS	—	235
27.1	0.92	9	480	3	11	12	23	31	37	CSSB-009A	NS	—	235
36.2	1.22	12	208	3	34	8	23	31	37	CSSB-012A	NS	—	240
36.2	1.22	12	240	3	29	10	23	31	37	CSSB-012A	NS	—	240
36.2	1.22	12	480	3	15	12	23	31	37	CSSB-012A	NS	—	240
51.2	1.73	17	208	3	48	6	23	31	37	CSSB-018A	NS	—	245
51.2	1.73	17	240	3	42	6	23	31	37	CSSB-018A	NS	—	245
51.2	1.73	17	480	3	21	12	23	31	37	CSSB-018A	NS	—	245
72.3	2.45	24	208	3	67	4	28	35	44	CSSB-024A	NS	—	300
72.3	2.45	24	240	3	58	4	28	35	44	CSSB-024A	NS	—	300
72.3	2.45	24	480	3	29	10	28	35	44	CSSB-024A	NS	—	300
87.4	2.95	29	208	3	81	3	28	35	44	CSSB-030A	NS	—	310
87.4	2.95	29	240	3	70	4	28	35	44	CSSB-030A	NS	—	310
87.4	2.95	29	480	3	35	8	28	35	44	CSSB-030A	NS	—	310
102.5	3.47	34	208	3	95	2	28	35	44	CSSB-036A	NS	—	315
102.5	3.47	34	240	3	82	3	28	35	44	CSSB-036A	NS	—	315
102.5	3.47	34	480	3	41	6	28	35	44	CSSB-036A	NS	—	315
138.7	4.69	46	208	3	128	2/0	28	35	44	CSSB-048A	NS	—	320
138.7	4.69	46	240	3	111	1	28	35	44	CSSB-048A	NS	—	320
138.7	4.69	46	480	3	56	6	28	35	44	CSSB-048A	NS	—	320
174.8	5.91	58	208	3	161	3/0	28	35	44	CSSB-060A	NS	—	380
174.8	5.91	58	240	3	140	2/0	28	35	44	CSSB-060A	NS	—	380
174.8	5.91	58	480	3	70	4	28	35	44	CSSB-060A	NS	—	380
205	6.93	68	208	3	189	250 MCM	28	35	44	CSSB-072A	NS	—	390
205	6.93	68	240	3	164	3/0	28	35	44	CSSB-072A	NS	—	390
205	6.93	68	480	3	82	3	28	35	44	CSSB-072A	NS	—	390
CSSB-A with Two Operating Pressure Controls³ (Transformer Optional)													
307	10.4	102	208	3	284	400 MCM	32	38	58	CSSB-100A	NS	—	625
307	10.4	102	240	3	246	350 MCM	32	38	58	CSSB-100A	NS	—	625
307	10.4	102	480	3	123	1/0	32	38	58	CSSB-100A	NS	—	625
410	13.6	136	240	3	327	600 MCM	32	38	64	CSSB-135A	NS	—	785
410	13.6	136	480	3	164	3/0	32	38	64	CSSB-135A	NS	—	785
475	16.1	158	240	3	379	700 MCM	32	38	64	CSSB-160A	NS	—	785
475	16.1	158	480	3	190	250 MCM	32	38	64	CSSB-160A	NS	—	785
542	18.4	180	240	3	433	2-300 MCM	32	38	64	CSSB-180A	NS	—	790
542	18.4	180	480	3	217	300 MCM	32	38	64	CSSB-180A	NS	—	790

Stock Status: S = stock AS = assembly stock NS = non-stock
To Order—Specify model, volts, phase and kW.

- Steaming capacity based on producing saturated steam at 212°F with 50°F feed water.
- Single phase and other voltages available. Contact your Local Chromalox Sales office.
- All boilers have 120V/1/60Hz control circuit. 220V/1/50Hz circuits are available for export boilers.
- Copper 90°C AWG unless indicated otherwise. Contact your Local Chromalox Sales office for the size and number of contactors.
- Allow 21" for element removal and 10" around boiler for service access. Add 2" to width dimension for optional transformer.

Dimensions (Inches)

CSSB-6A through -18A

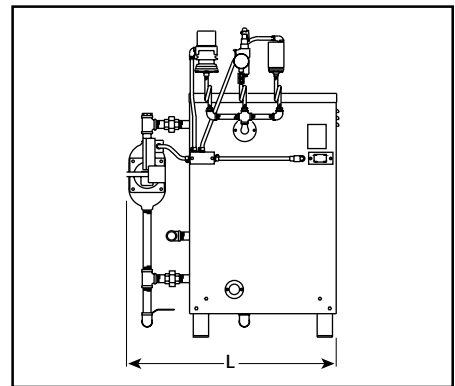
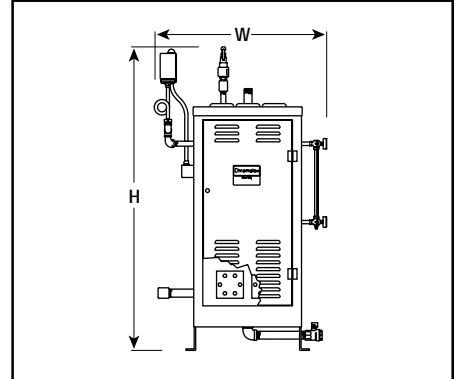

CSSB-24A through -72A

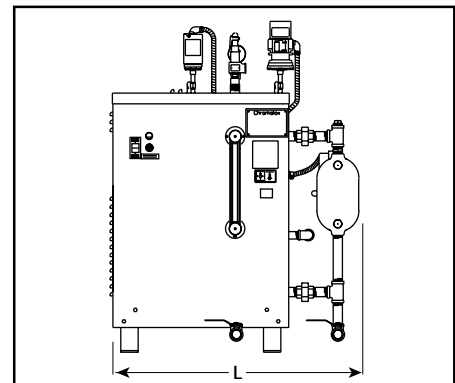
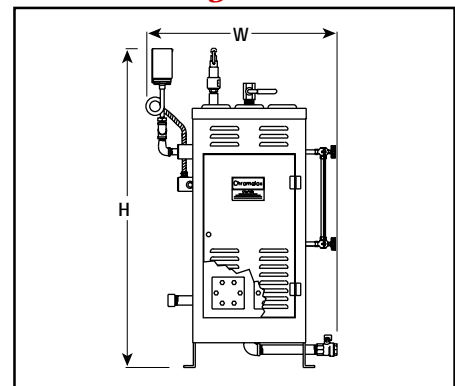

Plumbing Connections

Boiler	NPT	
	Water Inlet	Steam Outlet
CSSB 6-18	1/2	1/2
CSSB 24-72	3/4	1
CSSB 100	3/4	1-1/2
CSSB 135-180	3/4	2