



CHS

High Capacity Horizontal Steam Boiler



- Steam Pressures to 135 psig
- Steam Capacity (452 - 4,882 Lbs/Hr @ 0 - 135 psig)
- 150 - 1,620 kW (512 - 5,527 Mbh)
- 208, 240 and 480 Volt, 1 & 3 Phase
- ASME Section I Pressure Vessel Carbon Steel Code "S" (150 psig)
- 0.475 Dia. Copper Sheath Heating Elements
- Two or Three Operating Controls with Contactor Panels (150 - 300 kW)
- Proportional Operating Control with Sequencer and Contactor Panels (above 300 kW)
- Manual Reset High Limit Control with Stop at 90% of Safety Valve Setting
- Mechanical Float Water Feed Control with Low Water Cutoff
- Auxiliary Low Water Cutoff (Solid State) Control
- Pressure Gauge, Water Level Sight Glass and Double Blow Down Drain Valves
- ASME Safety Relief Valve (Two on Boilers Over 1,100 kW)

Applications

CHS High Capacity Steam Boilers are uniquely designed for larger commercial applications, laboratories, hospitals and industrial plants. CHS boilers are ideal for stand-by operations requiring high pressure steam in remote areas of an industrial plant which might incur excessive pipe losses or expensive piping costs to supply from a central steam supply. CHS boilers are particularly suited for use in off season periods when steam is needed for critical processes or humidification and the main boiler is shut down.

Features

CHS Stock Boilers are Trimmed at 150 psig for operation up to 135 psig corresponding to 353°F. They are also available with 15, 30, 50 and 100 psig trim. All catalog CHS boilers are UL Listed.

Water Feed (Pump) Control and Low Water Cutoff (McDonnell Miller #157) automatically maintains correct water level and shuts off the boiler when the water level in the boiler drops below safe limits.

Water Level Sight Glass allows for constant visual observation of the water level in the boiler during operation.

Auxiliary Low Water Cutoff — Solid state control board with low voltage probe provides backup protection for low water level in the boiler.

Steam Pressure Gauge with a range to 250 psig provided for visual indication of steam pressure.

Long Life Heating Elements — Conservatively rated flange mounted 0.475" dia. copper sheath heating elements provide uniform water circulation and long life.

Full Port Blow Down Drain Valves — Two heavy duty gate or ball valves connected in series for high pressure are supplied for boiler blow down.

Integral Electrical Controls and Power Panels with fuses and contactors mounted in heavy gauge control cabinet(s) with hinged doors and captive fasteners.

Control Circuits are 120V/1/60 Hz (Standard) — 220V/1/50 Hz control circuits are available for export boilers. Transformers are optional.

Manual On-Off Switch allows boiler control and power circuits to be shut down locally.

Pilot Light visually indicates when boiler control circuit is energized and the boiler is operating.

Fiberglas® Insulation material around the entire pressure vessel minimizes heat loss and helps reduce energy costs.

Plumbing Connections

Boiler	Water Inlet (NPT)	Steam Outlet (150 Lb. Flanged)
CHS 150-420	1	4"
CHS 495-945	1	6"
CHS 1080-1620	1-1/2	6"

A water feed or condensate return system is required on all CHS boilers. See Optional Equipment.

CHS

High Capacity Horizontal Steam Boiler (cont'd.)

Low Pressure Feed Water Systems for boilers up to 540 kW. Feed water must be at least 10 psi greater than the operating pressure of the boiler. (Condensate return systems are recommended for higher kW boilers.)

High Pressure Feed Water Systems for boilers up to 300 kW. (Condensate return systems are recommended for higher kW boilers.)

Condensate Return System for recovery of steam condensate for boiler water feed. (Recommended for all CHS boilers.)

Heavy Duty Vacuum Breaker prevents siphoning of condensate in condensate return systems.

Automatic Blow Down System eliminates need for daily manual blow-down maintenance.

Blow Down Separator for blow down of a boiler where steam and hot water cannot be discharged directly into a drain. Blow down separators are available with optional pressure gauge and/or temperature gauge.

Transformers for control circuit power (up to 2.0 kVA).

Low Pressure Trim for 15, 30, 50 and 100 psig.

Ammeter for visual indication of line current and boiler electrical load.

Pilot Lights for visual indication of sequencer operation and element staging.

Motor Starter for feed water pumps or condensate return system.

Proportional Control with electronic solid state sequencer for modulated pressure control.

Higher Pressure Trim up to 300 psig available on special order.

Contact your Local Chromalox Sales office for detailed information on these and other options for CHS boilers.

Dimensions (Inches)

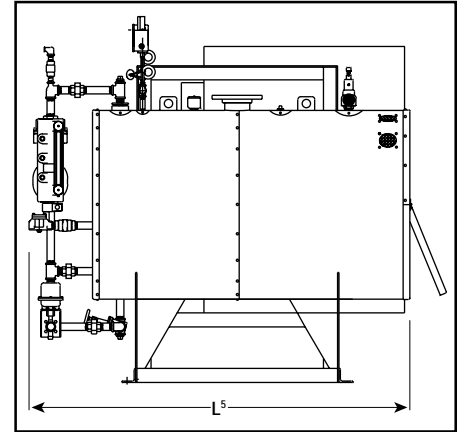
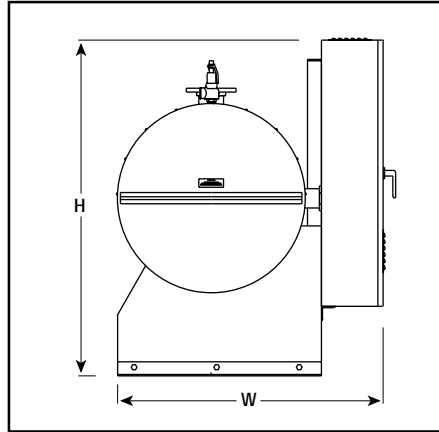

Specifications and Ordering Information

Steam ¹ Lbs/Hr	Bhp	kW	3 Ph ²		Service Wire ⁴ No. & Size	Dimensions (In.)			Model	Stock	Wt. (Lbs.)
			Volts ²	Amps ²		W	L ³	H			
CHS with Two Operating Pressure Controls (Two Stages)											
452	15.3	150	240	361	2 - 4/0	48	67	61	CHS-150A	NS	1,300
452	15.3	150	480	181	1 - 4/0	48	67	61	CHS-150A	NS	1,300
543	18.4	180	240	433	2 - 250 MCM	48	67	61	CHS-180A	NS	1,320
543	18.4	180	480	217	1 - 250 MCM	48	67	61	CHS-180A	NS	1,320
633	21.4	210	240	506	2 - 350 MCM	48	67	61	CHS-210A	NS	1,380
633	21.4	210	480	253	1 - 350 MCM	48	67	61	CHS-210A	NS	1,380
723	24.5	240	240	578	2 - 500 MCM	48	67	61	CHS-240A	NS	1,420
723	24.5	240	480	289	1 - 400 MCM	48	67	61	CHS-240A	NS	1,420
CHS with Three Operating Pressure Controls (Three Stages)											
814	27.6	270	240	650	2 - 600 MCM	48	67	61	CHS-270A	NS	1,480
814	27.6	270	480	325	1 - 600 MCM	48	67	61	CHS-270A	NS	1,480
904	30.6	300	240	722	2 - 600 MCM	48	67	61	CHS-300A	NS	1,530
904	30.6	300	480	361	1 - 600 MCM	48	67	61	CHS-300A	NS	1,530
CHS with Proportional Operating Pressure Control and Sequencer(s)											
1,085	36.7	360	480	433	2 - 250 MCM	48	67	61	CHS-360A	NS	1,600
1,266	42.9	420	480	506	2 - 350 MCM	48	67	61	CHS-420A	NS	1,700
1,492	50.5	495	480	596	2 - 500 MCM	54	85	61	CHS-495A	NS	2,100
1,628	55.1	540	480	650	2 - 600 MCM	54	85	61	CHS-540A	NS	2,200
1,899	64.3	630	480	758	2 - 700 MCM	54	85	61	CHS-630A	NS	2,300
2,170	73.5	720	480	866	3 - 400 MCM	54	85	61	CHS-720A	NS	2,800
2,441	82.7	810	480	975	3 - 600 MCM	54	85	61	CHS-810A	NS	3,000
2,848	96.4	945	480	1,137	3 - 700 MCM	54	85	61	CHS-150A	NS	3,200
3,255	110	1,080	480	1,299	4 - 500 MCM	75	85	61	CHS-1080A	NS	3,400
3,662	124	1,215	480	1,461	4 - 700 MCM	75	85	61	CHS-1215A	NS	3,600
4,069	138	1,350	480	1,624	5 - 600 MCM	75	85	61	CHS-1350A	NS	3,800
4,476	152	1,485	480	1,785	5 - 700 MCM	81	85	61	CHS-1485A	NS	4,000
4,883	165	1,620	480	1,949	6 - 600 MCM	81	85	61	CHS-1620A	NS	4,200

To Order—Specify model, volts, phase, kW, trim and Certification if required.

1. Steaming capacity based on producing saturated steam at 212°F with 50°F feed water.
2. All boilers are connected for three phase. Other voltages and ratings available.
3. Allow 32" for element removal on CHS 150 - 420 and 54" for CHS 495 - 1,620.
4. Copper 90°C AWG unless indicated otherwise. Contact your Local Chromalox Sales office for number and size of contactors.