



CHPES-A

Medium Pressure Vertical Steam Boiler

- Steam Pressures to 235 psig
- Steam Capacity (18 - 542 Lbs/Hr @ 0 - 235 psig)
- 6 - 180 kW (21 - 614 Mbh)
- 208, 240 and 480 Volt, 1 & 3 Phase
- ASME Section I Pressure Vessel Carbon Steel Code "S" (250 psig)
- 0.430 Dia. Copper Sheath Heating Elements
- One or Two Operating Controls Manual Reset High Limit
- Mechanical Float Water Feed Control with Low Water Cutoff
- Pressure Gauge, Water Level Sight Glass and Blow Down Drain Valve(s)
- ASME Safety Relief Valve

Applications

CHPES Medium Pressure Steam Boilers can be used wherever steam and process temperatures up to 400°F are required. CHPES boilers produce steam at pressures and temperatures considerably higher than CES models which are limited to 135 psig and 359°F.

CHPES Boilers are ideal for stand-by operations requiring steam in remote areas of an industrial plant which might incur excessive pipe losses or expensive piping costs to supply from a central steam supply. They are ideal for off season periods when steam is needed for critical processes when the main boiler is shut down.



CHPES Boilers are Trimmed at 250 psig for operation up to 235 psig, come complete, factory tested and ready to operate. CHPES boilers are UL Listed.

Features

250 Lb Medium Pressure Construction — Pressure vessel is manufactured to the requirements of ASME Section I and code stamped "S".

Water Feed (Pump) Control and Low Water Cutoff (McDonnell Miller #194) automatically maintains correct water level and shuts off the boiler when the water level in the boiler drops below safe limits.

Operating Controls — Pressure control(s) provide accurate regulation of steam pressure.

High Limit Pressure Control — Manual reset pressure limit control shuts down boiler if maximum operating pressure is exceeded.

Water Level Sight Glass — Provides for constant visual observation of the water level in the boiler.

Steam Pressure Gauge with a range to 600 psig provided for visual indication of steam pressure.

Drain and Blow Down Valves — Facilitate cleaning the boiler during blow down sequence.

Optional Equipment

Auxiliary Electronic Low Water Cutoff — Solid State control board with low voltage probe provides backup protection for low water level in the boiler. This option is required by some state or local boiler codes.

Proportional Control with electronic solid state sequencer for modulated pressure control.

Electronic Level Control with automatic water feed and low water cutoff (dual probe). Low cost alternative to mechanical float type water feed control and low water cutoff.

High Pressure Water Feed System for remote installation.

Condensate Return System for recovery of steam condensate for boiler water feed.

Heavy Duty Vacuum Breaker prevents siphoning of condensate in condensate return systems.

Automatic Blow Down System eliminates need for daily manual blow-down maintenance.

Blow Down Separator for blow down of a boiler where steam and hot water cannot be discharged directly into a drain.

Note — A water feed or condensate return system is required on all CHPES boilers. See Optional Equipment.

CHPES-A

Medium Pressure

Vertical Steam Boiler (cont'd.)

Specifications and Ordering Information

Steam ¹ Lbs/Hr	Bhp	kW	Volts ²	Ph	3 Ph ² Amps	Service ⁴ Wire Size	Dimensions (In.)			Model	Stock	PCN	Wt. (Lbs.)
							W	L ⁵	H				
CHPES with One Operating Pressure Control³ (Transformer Optional)													
18.1	0.61	6	208	3	17	12	23	31	37	CHPES-006A	NS	—	400
18.1	0.61	6	240	3	15	12	23	31	37	CHPES-006A	NS	—	400
18.1	0.61	6	480	3	8	12	23	31	37	CHPES-006A	NS	—	400
27.1	0.92	9	208	3	25	10	23	31	37	CHPES-009A	NS	—	430
27.1	0.92	9	240	3	22	10	23	31	37	CHPES-009A	NS	—	430
27.1	0.92	9	480	3	11	12	23	31	37	CHPES-009A	NS	—	430
36.2	1.22	12	208	3	34	8	23	31	37	CHPES-012A	NS	—	430
36.2	1.22	12	240	3	29	10	23	31	37	CHPES-012A	NS	—	430
36.2	1.22	12	480	3	15	12	23	31	37	CHPES-012A	NS	—	430
51.2	1.73	17	208	3	48	6	23	31	37	CHPES-018A	NS	—	430
51.2	1.73	17	240	3	42	6	23	31	37	CHPES-018A	NS	—	430
51.2	1.73	17	480	3	21	12	23	31	37	CHPES-018A	NS	—	430
72.3	2.45	24	208	3	67	4	28	35	44	CHPES-024A	NS	—	520
72.3	2.45	24	240	3	58	4	28	35	44	CHPES-024A	NS	—	520
72.3	2.45	24	480	3	29	10	28	35	44	CHPES-024A	NS	—	520
87.4	2.95	29	208	3	81	3	28	35	44	CHPES-030A	NS	—	520
87.4	2.95	29	240	3	70	4	28	35	44	CHPES-030A	NS	—	520
87.4	2.95	29	480	3	35	8	28	35	44	CHPES-030A	NS	—	520
102.5	3.47	34	208	3	95	2	28	35	44	CHPES-036A	NS	—	520
102.5	3.47	34	240	3	82	3	28	35	44	CHPES-036A	NS	—	520
102.5	3.47	34	480	3	41	6	28	35	44	CHPES-036A	NS	—	520
138.7	4.69	46	208	3	128	2/0	28	35	44	CHPES-048A	NS	—	630
138.7	4.69	46	240	3	111	1	28	35	44	CHPES-048A	NS	—	630
138.7	4.69	46	480	3	56	6	28	35	44	CHPES-048A	NS	—	630
174.8	5.91	58	208	3	161	3/0	28	35	44	CHPES-060A	NS	—	640
174.8	5.91	58	240	3	140	2/0	28	35	44	CHPES-060A	NS	—	640
174.8	5.91	58	480	3	70	4	28	35	44	CHPES-060A	NS	086510	640
205	6.93	68	208	3	189	250 MCM	28	35	44	CHPES-072A	NS	—	640
205	6.93	68	240	3	164	3/0	28	35	44	CHPES-072A	NS	—	640
205	6.93	68	480	3	82	3	28	35	44	CHPES-072A	NS	—	640
CHPES with Two Operating Pressure Controls³ (Transformer Optional)													
307	10.4	102	208	3	284	400 MCM	32	38	64	CHPES-100A	NS	—	1,250
307	10.4	102	240	3	246	350 MCM	32	38	64	CHPES-100A	NS	—	1,250
307	10.4	102	480	3	123	1/0	32	38	64	CHPES-100A	NS	109410	1,250
410	13.6	136	240	3	327	600 MCM	32	38	64	CHPES-135A	NS	—	1,400
410	13.9	136	480	3	164	3/0	32	38	64	CHPES-135A	NS	—	1,400
475	16.1	158	240	3	379	700 MCM	32	38	64	CHPES-160A	NS	—	1,450
475	16.1	158	480	3	190	250 MCM	32	38	64	CHPES-160A	NS	—	1,450
542	18.4	180	240	3	433	2-300 MCM	32	38	64	CHPES-180A	NS	—	1,500
542	18.4	180	480	3	217	300 MCM	32	38	64	CHPES-180A	NS	—	1,500

Stock Status: S = stock AS = assembly stock NS = non-stock
To Order—Specify model, volts, phase, kW and PCN.

- Steaming capacity based on producing saturated steam at 212°F with 50°F feed water.
- Single phase and other voltages available. Contact your Local Chromalox Sales office.
- All boilers have 120V/1/60Hz control circuit. 220V/1/50Hz circuits are available for export boilers.
- Copper 90°C AWG unless indicated otherwise. Refer to the instruction sheet for the number of contactors.
- Allow 21" for element removal and 10" around boiler for service access. Add 2" to width dimension for optional transformer.

Dimensions (Inches)

CHPES-6A through -18A

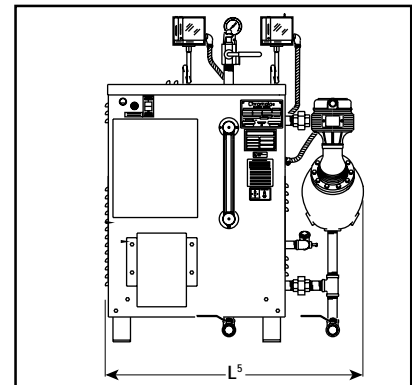
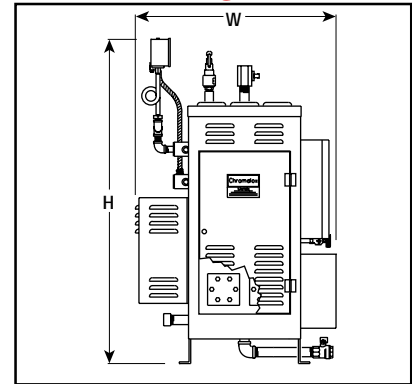

CHPES-24A through -180A

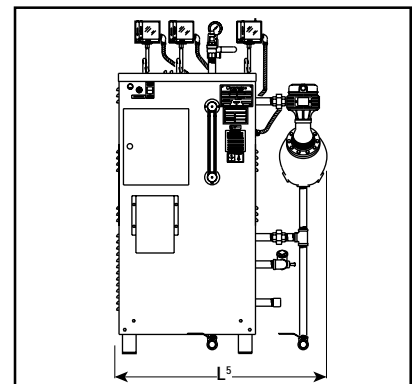
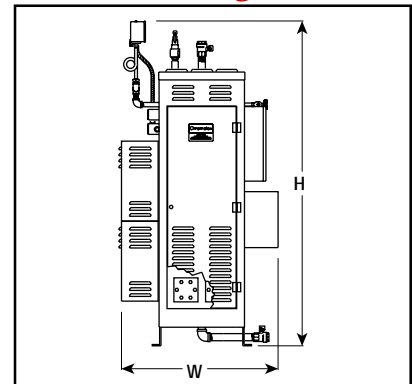

Plumbing Connections

Boiler	NPT	
	Water Inlet	Steam or Water Outlet
CHPES 6-18	1/2	1/2
CHPES 24-72	3/4	1
CHPES 100	3/4	1-1/2
CHPES 135-180	3/4	2