

CP Series

Wide Area Radiant Heaters

- 5 - 25 W/In²
- 0.55 - 18 kW
- 120, 230, 240 and 480 Volt
- 1 & 3 Phase
- 1650°F Max. Emitter Temp.
- 6 - 60" Long x 12 - 30" Wide

Applications

- Ink Drying and Spot Curing for Printing and Silk Screening
- Food Warming
- Moisture Removal in Food Processing
- Plastics Annealing
- Preheat and Postheat Plastics prior to Thermoforming and Punching
- Thermoforming and Vacuum Forming
- Heat Treating Plastic Parts
- Baking or Curing of Lacquers, Semi-Enamels, Enamels, Primers, Phenolics and Epoxies
- Finishing Process of Textiles
- Preheat Printed Circuit Boards

Features

Easy Mounting — Heater can be mounted to radiate in any direction.

Reliable Operation — No reduction in radiant output over life of heater.

Uniform Radiation Pattern Assured with a wide flat infrared surface versus the line pattern given in normal radiant heaters. This eliminates uneven heating of the work and allows uniform heating of a stationary surface such as in an indexing process.

External Reflectors Not Required — The refractory board and bulk insulation behind the heating element help prevent back heat loss. This eliminates the need for external reflectors.

One-Piece Bonded Construction resists damage from vibration and shock.

Overtemperature Control — These units should be controlled such that overheating and premature failure do not occur.

Additional Sizes and Ratings — Contact your Local Chromalox Sales office for price and availability.

Lower Operating Cost with up to 80% of the input energy transmitted to and absorbed by the work material. The maximum amount of radiant energy is transferred to the work with very low heater convection losses. Typical installation distance of two to four inches from the work surface significantly reduces the energy input.

Costly Downtime Minimized — There is no deterioration of the output radiation level with heater life and no reflectors to clean which could cause downtime and increased maintenance costs. The unit is resistant to vibration because of the compact homogeneous construction.

Easy Installation — The light weight building block approach allows for a modular installation which is easily expandable. These rugged panels can be mounted in any direction.

Repeatable Process Performance Assured — Used with closed loop control, the system automatically compensates for ambient temperature ranges and line voltage fluctuations. Maximum energy transfer requires matching the peak wavelength output to the specific material absorption characteristics. Because the peak wavelengths of the flat surface heater are repeatable and adjustable, the quality output of the process is assured.

Construction

1. **Heating Element** — Precision iron base resistance wire, designed to give extended life and uniform emission over entire radiating surface.
2. **Emission Surface** — Woven refractory cloth with black ceramic coating for high radiant energy transfer for CPLI, CPL and CPH type heaters. Aluminum emission surfaces are available for applications such as in the food industry.
3. **Frame** — Heavy gauge, heat resistant, aluminized steel for CPLI, CPL and CPH type heaters.
4. **Heating Element Support** — Fibrous ceramic material, specially developed for high insulation qualities, durability, shock resistance, asbestos free.
5. **Insulation** — High temperature insulation to minimize heat loss from back of heater.
6. **Terminals** — For CPLI, lead-wires are provided on a 2 x 4" junction box. A 2 x 4" junction box with stainless steel terminals is provided for CPL and CPH type heaters.
7. **Thermowell** — Quality tubular quartz thermowell, with strain relief, to accept a Chromalox C-700JU or C-700KU thermocouple on units with suffix T in model number. Standard placement of the thermowell is on side of heater. Specials are available with thermowell exiting back of heater.

Construction

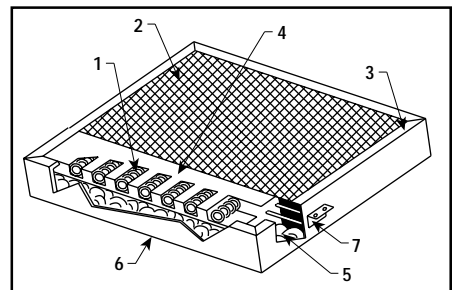

CP Series

Wide Area Radiant Heaters (cont'd.)

The CPH, CPL and CPLI are medium wave heaters. Micron levels between 2.5 and 6 of infrared energy are generated. At these micron levels the majority of the infrared energy generated falls into the medium wave section of the infrared spectrum.

Outer edges of the element can have gradual increasing wattage density to compensate for production edge losses.

Single elements or multiple elements can be zoned and wired to achieve specific profiles. Different width materials can be processed by turning off elements.

Easy to Control — The use of time proportioning control with closed loop feedback, such as Chromalox 2104 temperature controllers, magnetic contactors or SCR power controllers assure easy and dependable system control. Thermowells may be offered in two locations in the heater interior. Suitable to accept Chromalox standard thermocouples, they sense emitter temperature ensuring accurate wavelength emission. Fast response time of the unit reduces thermal lag.

Overtemperature Control — It is strongly recommended that these units be controlled such that overheating and premature failure do not occur. This is of particular importance in oven usage, where high ambient temperatures exist.

CAUTION — Hazard of Fire. These radiant heaters must not be operated in the presence of flammable vapors, gases or combustible materials without proper ventilation and/or other safety precautions in compliance with either the National Fire Protection Bulletin 86A entitled "Ovens and Furnaces" or the authority having jurisdiction.



CPH & CPL — Dimensions (Inches)

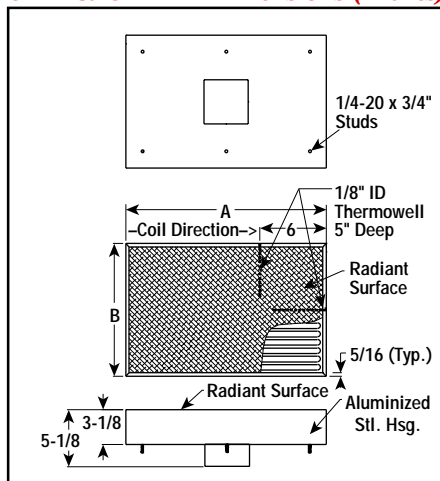

CPLI — Dimensions (Inches)

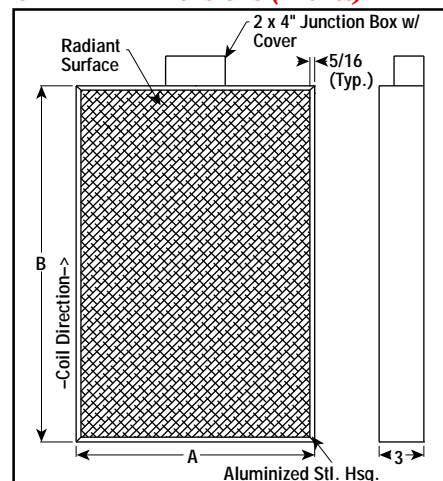

Specifications and Ordering Information

kW	Volts	Phase	W/In ²	DIM (In.)		Thermo-well	Mtg. Studs	Model	Stock	PCN	Wt. (Lbs.)
				A	B						
1.1	120/240	1	15	6	12	Yes	2	CPL-0612T	S	223790	3
1.8	240/480	1	25	6	12	Yes	2	CPH-0624T	S	223802	3
1.3	230	1	10	12	12	No	4	CPLI-1212-13	NS	224506	6
2.2	240/480	1	15	12	12	Yes	4	CPL-1224T	S	223810	6
3.6	240/480	1	25	12	12	No	4	CPH-1224	S	223829	6
3.6	240/480	1	25	12	12	Yes	4	CPH-1224T	S	223837	6
1.8	230	1	5	16	16	No	4	CPLI-1616-18	S	224514	11
0.55	230	1	5	6	18	No	2	CPLI-0618-05	NS	224469	5
1	230	1	10	6	18	No	2	CPLI-0618-10	NS	224477	5
1.3	230	1	10	6	24	No	2	CPLI-0624-13	NS	224485	6
3.5	230	1	10	16	24	No	4	CPLI-1624-35	S	224522	16
3.75	230	1	5	24	24	No	4	CPLI-2424-37	S	224530	24
4.3	240/480	1	15	24	12	Yes	4	CPL-2424T	S	223845	12
7.2	240	3	25	24	12	No	4	CPH-2423	S	223853	12
7.2	240	3	25	24	12	Yes	4	CPH-2423T	S	223861	12
7.2	480	3	25	24	12	No	4	CPH-2443	S	223870	12
7.2	480	3	25	24	12	Yes	4	CPH-2443T	S	223888	12
1.55	230	1	10	6	30	No	2	CPLI-0630-15	NS	224493	8
8.6	240	3	15	48	12	Yes	6	CPL-4823T	S	223896	24
8.6	480	3	15	48	12	No	6	CPL-4843	S	223909	24
8.6	480	3	15	48	12	Yes	6	CPL-4843T	S	223917	24
14.4	240	3	25	48	12	Yes	6	CPH-4823T	S	223925	24
14.4	480	3	25	48	12	Yes	6	CPH-4843T	S	223933	24
10.8	480	3	15	60	12	Yes	6	CPL-6043T	S	223941	30
18	240	3	25	60	12	Yes	6	CPH-6023T	S	223950	30
18	480	3	25	60	12	Yes	6	CPH-6043T	S	223968	30

Stock Status: S = stock AS = assembly stock NS = non-stock
To Order— Specify model, PCN, kW, volts, phase and quantity.

Wide Area