

## CAB & CABB

### Low Temperature Air Duct Heaters

- Side Terminals (type CAB)
- Bottom Terminals (type CABB)
- 6 - 100 kW
- 120, 208, 240 and 480 Volt
- 1 or 3 Phase
- Rust-Resisting Iron or Chrome Steel Sheath Elements
- 440°F Max. Outlet Air Temp.

#### Applications

- Sole Heat Source
- Booster Heater in Process and Comfort Heating Ducts
- Convert existing Forced Air Dryers and Ovens
- With Blower and Duct, can be used to Fabricate simple Forced Air Drying Unit

#### Features

**Simple Duct Transition Sections** may be used to adapt standard heater sizes to various duct sizes to increase air velocities for better heat transfer, lower sheath temperature and longer element life.

**Field Wiring Terminals** — Heavy duty 3/8" diameter bolts of either brass (iron sheath units) or Stainless Steel (chrome steel sheath units) with necessary hardware are provided for field wiring connections. Terminals are located on the side for CAB units and on the bottom for CABB units, and should be on the outside of ducting.

**Fins** of aluminized steel are provided to improve heat transfer to the air.

**Elements** are individually replaceable.

**Terminal Cover Option** is available to prevent accidental contact with live electrical terminals (PCN 269720), one (1) required per circuit.

**MONEL® Sheath and MONEL® Fins** are available for humid conditions. Model TDH heaters, using Fintube® elements are also available. Contact your Local Chromalox Sales office.

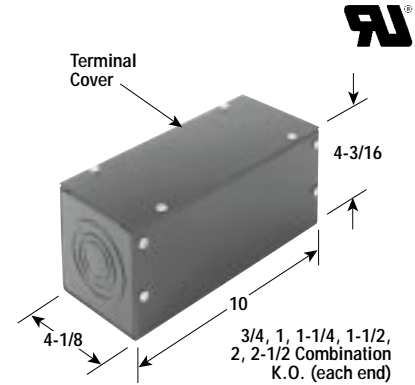

#### Dimensions (Inches)

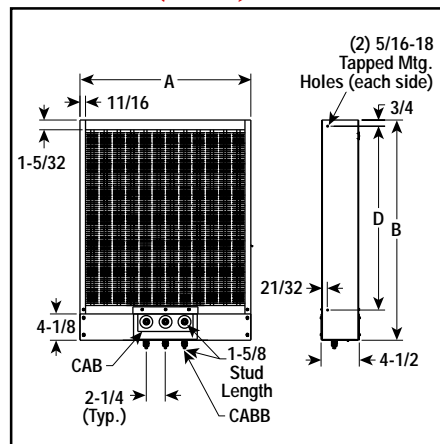

#### Construction

**Rugged Finstrip® Elements** are mounted in a sturdy steel frame with narrow side of elements and fins facing the air flow.

**Finstrip® Elements, Exclusive Construction** — High-quality, coiled resistor wire is uniformly spaced over the width and length of the Finstrip® element, then embedded in high-grade refractory material which insulates the wire and transfers heat rapidly. Refractory is then compressed to rock hardness and maximum density under tremendous hydraulic pressure to improve heat transfer from coil to sheath. Elements are oven baked at high temperatures to semi-vitrify and mature the refractory. Sheath material is either rust-resisting iron or chrome steel.

**Sturdy Steel Frame** — 14 gauge cold rolled steel painted with high heat resisting black enamel paint.

**Internal Electrical Connections** are made using a combination of buss bars and jumper straps consisting of either Manganese-Nickel or MONEL®.

#### Mounting

Always install heaters in duct work with terminal box on bottom of heater. Type CAB units should have field wiring terminals facing upstream to provide maximum cooling affect. Secure to duct work using mounting holes on both vertical sides of heater.

#### Overtemperature Protection

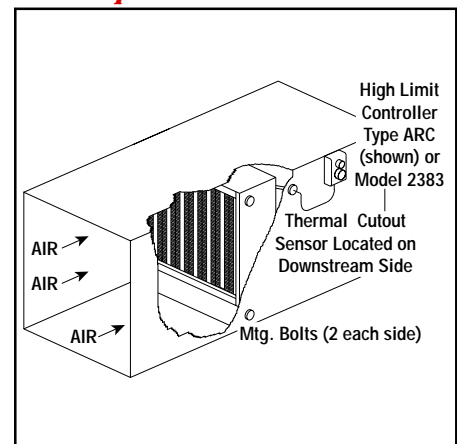

#### Application & Selection Guidelines

**Selection Heater Size** — Refer to Technical section for examples on determining kW requirements. For quick estimating purposes, the following formula may be used for air at standard conditions:

$$kW = \frac{SCFM \times \text{Temp. Rise } (^\circ F)}{3000}$$

**Maximum Work Temperatures** — Type CAB and CABB heaters can generally be used at the following maximum temperatures, provided the minimum air velocity is maintained uniformly through the heater.

Air Velocity (Ft./Sec.)	Max. Outlet Air Temp. (°F)	
	Iron Sheath	Chrome Steel Sheath
4	—	200
9	90	330
16	220	440

**Note** — Maximum temperatures are based on 26 W/In<sup>2</sup>. If elements have a lower watt density, work temperatures may be increased; if watt density is higher, work temperatures should be lower.

**Note** — See Allowable Watt Density & Heater Selection Graphs and Pressure Drop Curve G-112S1 under Air & Gas Heating Data in the Technical section of this catalog.

## CAB & CABB

### Low Temperature Air Duct Heaters *(cont'd.)*

#### Specifications and Ordering Information

kW	Volts	Phase	Amps/ Circ.	No. Circ.	No. Elem.	Dimensions (In.)			Rust-Resisting Iron Sheath Temperatures to 750°F			Chrome Steel Sheath Temperatures to 950°F			Wt. (Lbs.)
						A	B	D	Model	Stock	PCN	Model	Stock	PCN	
<b>CAB — Side Terminals (26 W/In<sup>2</sup>)</b>															
6	120	1	50	1	6	10-3/4	15-7/8	11-1/2	CAB-62	NS	260013	CAB-611	NS	260398	25
6	208	1	28.9	1	6	10-3/4	15-7/8	11-1/2	CAB-62	NS	260021	CAB-611	NS	260400	25
6	240	1	25	1	6	10-3/4	15-7/8	11-1/2	CAB-62	NS	260030	CAB-611	NS	260419	25
6	480	1	12.5	1	6	10-3/4	15-7/8	11-1/2	CAB-62	NS	260048	CAB-611	NS	260427	25
6	208	3	16.7	1	6	10-3/4	15-7/8	11-1/2	CAB-62	NS	260064	CAB-611	NS	260443	25
6	240	3	14.5	1	6	10-3/4	15-7/8	11-1/2	<b>CAB-62</b>	<b>S</b>	<b>260072</b>	<b>CAB-611</b>	<b>S</b>	<b>260451</b>	25
6	480	3	7.2	1	6	10-3/4	15-7/8	11-1/2	<b>CAB-62</b>	<b>S</b>	<b>260080</b>	<b>CAB-611</b>	<b>S</b>	<b>260460</b>	25
12	208	1	57.7	1	9	15-3/8	18-1/2	14-1/8	CAB-122	NS	260099	CAB-1211	NS	260478	35
12	240	1	50	1	9	15-3/8	18-1/2	14-1/8	CAB-122	NS	260101	CAB-1211	NS	260486	35
12	480	1	25	1	9	15-3/8	18-1/2	14-1/8	CAB-122	NS	260110	CAB-1211	NS	260494	35
12	208	3	33.4	1	9	15-3/8	18-1/2	14-1/8	CAB-122	NS	260128	CAB-1211	NS	260507	35
12	240	3	28.9	1	9	15-3/8	18-1/2	14-1/8	<b>CAB-122</b>	<b>S</b>	<b>260136</b>	<b>CAB-1211</b>	<b>S</b>	<b>260515</b>	35
12	480	3	14.5	1	9	15-3/8	18-1/2	14-1/8	<b>CAB-122</b>	<b>S</b>	<b>260144</b>	<b>CAB-1211</b>	<b>S</b>	<b>260523</b>	35
15	208	1	72.1	1	9	15-3/8	21-5/8	17-1/4	CAB-152	NS	260152	CAB-1511	NS	260531	40
15	240	1	62.5	1	9	15-3/8	21-5/8	17-1/4	CAB-152	NS	260160	CAB-1511	NS	260540	40
15	480	1	31.3	1	9	15-3/8	21-5/8	17-1/4	CAB-152	NS	260179	CAB-1511	NS	260558	40
15	208	3	41.7	1	9	15-3/8	21-5/8	17-1/4	CAB-152	NS	260187	CAB-1511	NS	260566	40
15	240	3	36.1	1	9	15-3/8	21-5/8	17-1/4	<b>CAB-152</b>	<b>S</b>	<b>260195</b>	<b>CAB-1511</b>	<b>S</b>	<b>260574</b>	40
15	480	3	18.1	1	9	15-3/8	21-5/8	17-1/4	<b>CAB-152</b>	<b>S</b>	<b>260208</b>	<b>CAB-1511</b>	<b>S</b>	<b>260582</b>	40
20	208	3	55.6	1	12	20-1/8	21-5/8	17-1/4	CAB-202	NS	260216	CAB-2011	NS	260590	55
20	240	3	48.2	1	12	20-1/8	21-5/8	17-1/4	CAB-202	NS	260224	<b>CAB-2011</b>	<b>S</b>	<b>260603</b>	55
20	480	3	24.1	1	12	20-1/8	21-5/8	17-1/4	CAB-202	NS	260232	<b>CAB-2011</b>	<b>S</b>	<b>260611</b>	55
25	208	3	69.5	1	12	20-1/8	26-1/8	21-3/4	CAB-252	NS	260240	CAB-2511	NS	260620	65
25	240	3	60.2	1	12	20-1/8	26-1/8	21-3/4	CAB-252	NS	260259	CAB-2511	NS	260638	65
25	480	3	30.1	1	12	20-1/8	26-1/8	21-3/4	CAB-252	NS	260267	<b>CAB-2511</b>	<b>S</b>	<b>260646</b>	65
30	480	3	18.1	2	18	29-1/2	21-5/8	17-1/4	—	—	—	<b>CAB-3011</b>	<b>S</b>	<b>279160</b>	75
40	208	3	55.6	2	18	29-1/2	27-3/8	23	CAB-402	NS	260275	CAB-4011	NS	260654	90
40	240	3	48.2	2	18	29-1/2	27-3/8	23	CAB-402	NS	260283	CAB-4011	NS	260660	90
40	480	3	24.1	2	18	29-1/2	27-3/8	23	CAB-402	NS	260291	<b>CAB-4011</b>	<b>S</b>	<b>260670</b>	90
50	208	3	69.5	2	18	29-1/2	33-1/8	28-3/4	CAB-502	NS	260304	CAB-5011	NS	260689	110
50	240	3	60.2	2	18	29-1/2	33-1/8	28-3/4	CAB-502	NS	260312	CAB-5011	NS	260697	110
50	480	3	30.1	2	18	29-1/2	33-1/8	28-3/4	CAB-502	NS	260320	<b>CAB-5011</b>	<b>S</b>	<b>260700</b>	110
75	208	3	69.5	3	27	44-7/16	42-1/8	37-3/4	CAB-752	NS	260339	CAB-7511	NS	260718	200
75	240	3	60.2	3	27	44-7/16	42-1/8	37-3/4	CAB-752	NS	260347	CAB-7511	NS	260726	200
75	480	3	30.1	3	27	44-7/16	42-1/8	37-3/4	CAB-752	NS	260355	<b>CAB-7511</b>	<b>S</b>	<b>260734</b>	200
100	208	3	92.6	3	27	44-7/16	47-1/2	43-1/8	CAB-1002	NS	260363	CAB-10021	NS	260742	220
100	240	3	80.3	3	27	44-7/16	47-1/2	43-1/8	CAB-1002	NS	260371	CAB-10021	NS	260750	220
100	480	3	40.1	3	27	44-7/16	47-1/2	43-1/8	CAB-1002	NS	260380	<b>CAB-10021</b>	<b>S</b>	<b>260769</b>	220
<b>CABB — Bottom Terminals (26 W/In<sup>2</sup>)</b>															
6	240	3	14.5	1	6	10-3/4	15-7/8	11-1/2	—	—	—	<b>CABB-611</b>	<b>S</b>	<b>266546</b>	25
6	480	3	7.2	1	6	10-3/4	15-7/8	11-1/2	—	—	—	<b>CABB-611</b>	<b>S</b>	<b>266554</b>	25
12	208	3	33.4	1	9	15-3/8	18-1/2	14-1/8	—	—	—	<b>CABB-1211</b>	<b>S</b>	<b>203860</b>	35
12	240	3	28.9	1	9	15-3/8	18-1/2	14-1/8	—	—	—	<b>CABB-1211</b>	<b>S</b>	<b>203801</b>	35
12	480	3	14.5	1	9	15-3/8	18-1/2	14-1/8	—	—	—	<b>CABB-1211</b>	<b>S</b>	<b>266562</b>	35
20	480	3	24.1	1	12	20-1/8	21-5/8	17-1/4	—	—	—	<b>CABB-2011</b>	<b>S</b>	<b>266570</b>	55
25	480	3	30.1	1	12	29-1/2	26-1/8	21-3/4	<b>CABB-252</b>	<b>S</b>	<b>266626</b>	<b>CABB-2511</b>	<b>S</b>	<b>266634</b>	65
40	480	3	24.1	2	18	29-1/2	27-3/8	23	<b>CABB-402</b>	<b>S</b>	<b>266669</b>	<b>CABB-4011</b>	<b>S</b>	<b>266642</b>	90
50	480	3	30.1	2	18	29-1/2	33-1/8	28-3/4	<b>CABB-502</b>	<b>S</b>	<b>266466</b>	<b>CABB-5011</b>	<b>S</b>	<b>266407</b>	110
75	480	3	30.1	3	27	44-7/16	42-1/8	37-3/4	<b>CABB-752</b>	<b>S</b>	<b>261120</b>	<b>CABB-7511</b>	<b>S</b>	<b>261147</b>	200
100	480	3	40.1	3	27	44-7/16	47-1/2	43-1/8	<b>CABB-1002</b>	<b>S</b>	<b>261139</b>	<b>CABB-10021</b>	<b>S</b>	<b>261166</b>	220

**Stock Status:** S = stock AS = assembly stock NS = non-stock  
**To Order**—Specify model, PCN, kW, volts and quantity.

#### Free Area for Air Flow

Model	Square Feet	Model	Square Feet
CAB-62 & 611	0.500	CAB-402 & 4011	3.29
CAB-122 & 1211	0.927	CAB-502 & 5011	4.13
CAB-152 & 1511	1.19	CAB-752 & 7511	8.25
CAB-202 & 2011	1.63	CAB-1002 & 10021	9.38
CAB-252 & 2511	2.07		

**Note** — The volume of air being circulated along with the free area for air flow (in table above) will enable you to calculate the air velocity over the heater.