



T190 UNIVERSAL PROGRAMMABLE THERMOSTAT

SMART ENERGY MANAGEMENT



HIGHLIGHTS

- Up to 3H/2C
- Heat Pump or Conventional Control
- Adjustable Stage Differentials
- 7 Day, 4 Event Programmable
- Non-Volatile Program Storage
- Program Override
- Filter and System Check Reminders
- Automatic LCD Backlight
- 24 VAC or Battery Powered
- Title 24 Compliant

Best Value

No control on the market offers a better combination of price, performance, and flexibility. When you look closely at the PECO T190, you'll see why distributors and contractors find PECO the undisputed value leader in universal, programmable thermostats.

Most Flexible Controls

The T190 from PECO meets a broad range of applications and feature requirements. Whether you are looking for a thermostat with single or multiple stages, conventional or heat pump, hardwired or battery powered - we've got you covered.

Broadest Range of Proactive Energy & Maintenance Control

The T190 allows users to manage their desire for comfort and energy savings by adjusting temperature control spans and differentials. Users can also monitor thermostat usage and set reminders for filter changes and system maintenance. Through the PECO Contractor Labeling Program, service providers have an ideal location to display information to assure future business.

T190 UNIVERSAL PROGRAMMABLE THERMOSTAT

TECHNICAL SPECIFICATIONS

Measurement Range	32-99°F (0-39.5°C)
Temperature Control	50-95°F (10-32°C)
Temperature Accuracy	+/- 1°F, 0.5°C,
Voltage & Frequency	24 VAC, 50/60 Hz
Load Connections	Terminal Blocks
Terminal Load	1A per terminal, 5A max
Sensing Element	NTC Thermistor
Memory	EEPROM
Power	Hardwired or 2-AA Batteries



WIRING DIAGRAM

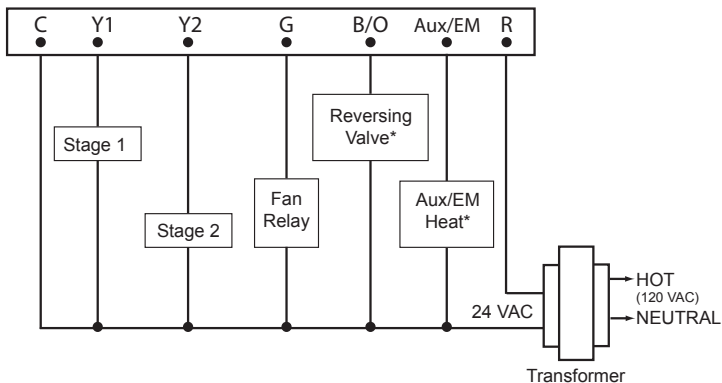

*Heat Pump Mode Only

MOUNTING INSTRUCTIONS

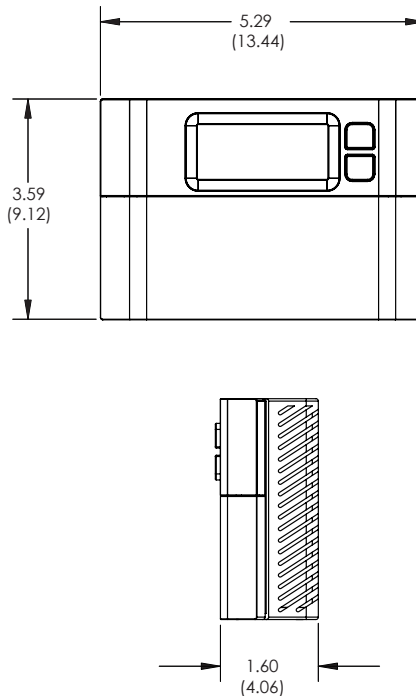

Represented By: Ross & Pethtel
 Phone: 225-273-2202 www.rosspethtel.com

