



5500/5510 SERIES RELAY DATA SHEET

SERIES 5500 NON-INTRINSICALLY SAFE MODULE

Series 5500 Control Module has all the same basic specifications, failsafe features, sensitivity, lead wire lengths, and wiring requirements as the 5510 Intrinsically Safe Module but does **NOT** have the necessary approvals for use with sensors in hazardous locations. The 5500 Control Module has a general purpose use approval by Underwriters Laboratory.

Applications of this module include use as a liquid level control device when used with electrode equipment or as a general control device when used from a remote pilot device. Since the sensing circuit provides a low voltage and low current signal, usage with hard water and corrosive chemicals will minimize buildup or erosion on the electrodes in liquid level applications. Use as an inexpensive control device from a distant pilot switch up to 2,500 feet away is recommended as long as twisted shielded cable is used.

SERIES 5510 INTRINSICALLY SAFE MODULE

Series 5510 Control Modules were developed especially to provide an intrinsically safe and economical means of detecting and controlling a wide range of processing variables in areas containing explosive atmospheric mixtures.

Tested and listed by UL for use in applications involving Class I, II and III locations, these compact solid-state modules are designed to prevent an external probe or pilot control circuit from releasing sufficient electrical energy to ignite even the most flammable gases or vapors classified in Groups A, B, C, D, and combustible dusts or fibers classified in Groups E, F, G.

SPECIFICATIONS

Dual Input Voltage:

110-120 VAC 50/60 Hz
(+10% / -20%)

Power Consumption:

2 Volt-Amperes, 1.5 watt Max.

Standard Contact Rating:

10 amperes resistive load at 277 VAC
or 30 VDC, 360 va 240 VAC - pilot duty
1/3 HP at 240 VAC, 1/4 HP at 120 VAC

Output Contact Arrangement:

Single pole, double throw

Ambient Temperatures:

-40° F to 180° F

-40° C to 82.2° C

Sensing Circuit:

Inherently limited to less than 11.3 milliamp at 11.3 volts AC to assure intrinsically safe operation under abnormal fault conditions



DIMENSIONAL DATA

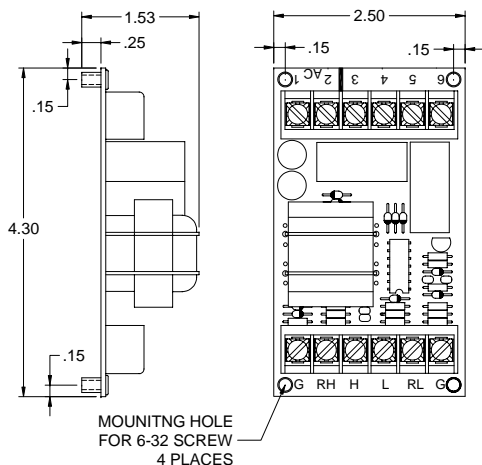

MOUNTING HOLE FOR 6-32 SCREW
4 PLACES

5500 SERIES RELAY
NON-INTRINSICALLY SAFE

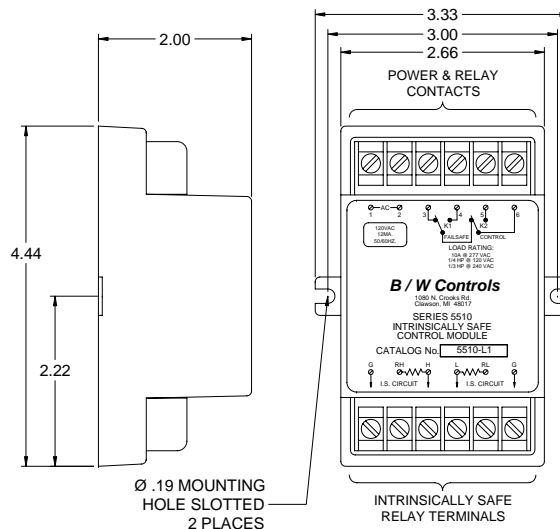

Ø .19 MOUNTING HOLE SLOTTED
2 PLACES

5510 SERIES RELAY
INTRINSICALLY SAFE



MODULE SENSITIVITY

Operating sensitivity is important only in level control applications where the module is operated from electrodes and the liquid is used as a conductor to complete the external sensing circuit. Since liquid resistances vary, various operating sensitivities can be field installed. In such applications, the module must have a sensitivity greater than the specific resistance of the liquid being controlled. One or two sensitivity resistors of equal value should be selected from the package provided and installed according to the application drawings and chart. When operated from a B/W 7014 Unifloat® multi-level sensing system, 7010 Float Switch or other pilot switching devices, a jumper wire(s) is recommended in place of the resistors(s).

Regardless of sensitivity rating, all B/W Series 5510 Modules are designed to operate continuously with external probe or pilot circuit resistances as low as zero without damaging the module. This permits intrinsically safe operation at all times from electrodes or pilot switches.

SENSITIVITY RESISTOR (OHMS)	OPERATING SENSITIVITY (OHMS)	MAXIMUM LEAD WIRE LENGTHS (FEET)	APPLICATION RECOMMENDATIONS
0-Jumper in place of Resistor	-----	2,500	7014 Unifloat, 7010 Float Switch, other dry contacts.
270	1,400	2,500	Strong or weak electrolytes, plating solutions ammonium hydroxide, borax, acetic acid
1,000	2,400	2,500	Most food processing; beer, wine, fruit juices, milk, buttermilk
3,900	5,900	2,500	Most water; highly corrosive acid or caustic solutions where current must be minimized to extend electrode life: hydrochloric & sulfuric acid
10,000	13,000	1,000	Water with medium to high mineral content; sewage, water soluble oil, starch solutions
22,000	26,000	450	Water with low mineral content; sugar syrup solutions
68,000	74,600	125	De-mineralized water (not distilled or de-ionized water – use 5200 H) steam condensate, corn syrup, strong alcohol solutions up to 50%

INSTALLATION

When mounted in an approved explosion-proof enclosure, B/W Series 5510 Modules can be located within a hazardous area, providing the power wiring *to the module and from the load contacts* are installed in accordance with applicable codes for the location. The most economical method of installation, however, is to mount the module in a non-hazardous environment and run the external control circuit through an approved seal to a pilot device or level sensing electrodes in the hazardous area.

As defined by the National Electrical Code, Factory Mutual and Underwriters Laboratories, an intrinsically safe control system consists of equipment and associated wiring that are inherently incapable of releasing sufficient electrical or thermal energy under normal or abnormal conditions to cause ignition of a specific hazardous atmospheric mixture at its most easily ignited concentration in air.

Abnormal conditions would include any two independent mechanical or electrical faults occurring simultaneously – such as accidental damage to any part of the equipment, wiring and installation, and any other failure of electrical components due to application of over-voltage, improper adjustment or maintenance, and other similar conditions.

When properly installed in accordance with the diagram as shown, Series 5510 Modules meet the most stringent requirement of UL for intrinsically safe operation from pushbuttons, pressure or float switches, thermostats, humidistat or any type of general-purpose pilot control device. In addition, probes or electrodes in contact with any conductive liquid or moist bulk material to perform a wide variety of mixing, measuring, metering and flow or level control functions may also actuate them.

In such installations, an inexpensive general-purpose enclosure may be used for both the control module and the pilot device. Wiring between the two may be of any type approved for non-hazardous locations without violating provisions of Article 500-517 of the National Electrical Code. It is essential that:

- (1) **An approved seal be used at the point where the intrinsically safe pilot control circuit enters the hazardous area, and**
- (2) **The pilot circuit wiring is to be isolated from other wiring.**

5500/5510 SERIES SOLID-STATE RELAY CATALOG NUMBERING SYSTEM

5500 or 5510 - L1 - N1

RELAY CODE	ENCLOSURE TYPE
OC	Open Chassis
N1	NEMA 1, General Purpose
N4	NEMA 4, Weather Proof, Watertight / Dust Tight
N4X	NEMA 4X, Fiberglass, Watertight, Dust Tight, Corrosion Resistant
N7	NEMA 7, Class I, Group D; Class II, Groups E, F & G
N12	NEMA 12, Oil Tight

RELAY CODE	LINE VOLTAGE
L1	110 - 120 VAC 50/60 Hz +10% -20%

RELAY CODE	RELAY TYPE
5500	Non-Intrinsically Safe Control Module
5510	Intrinsically Safe Control Module

INTRINSICALLY SAFE UNIT INSTALLATION DRAWING

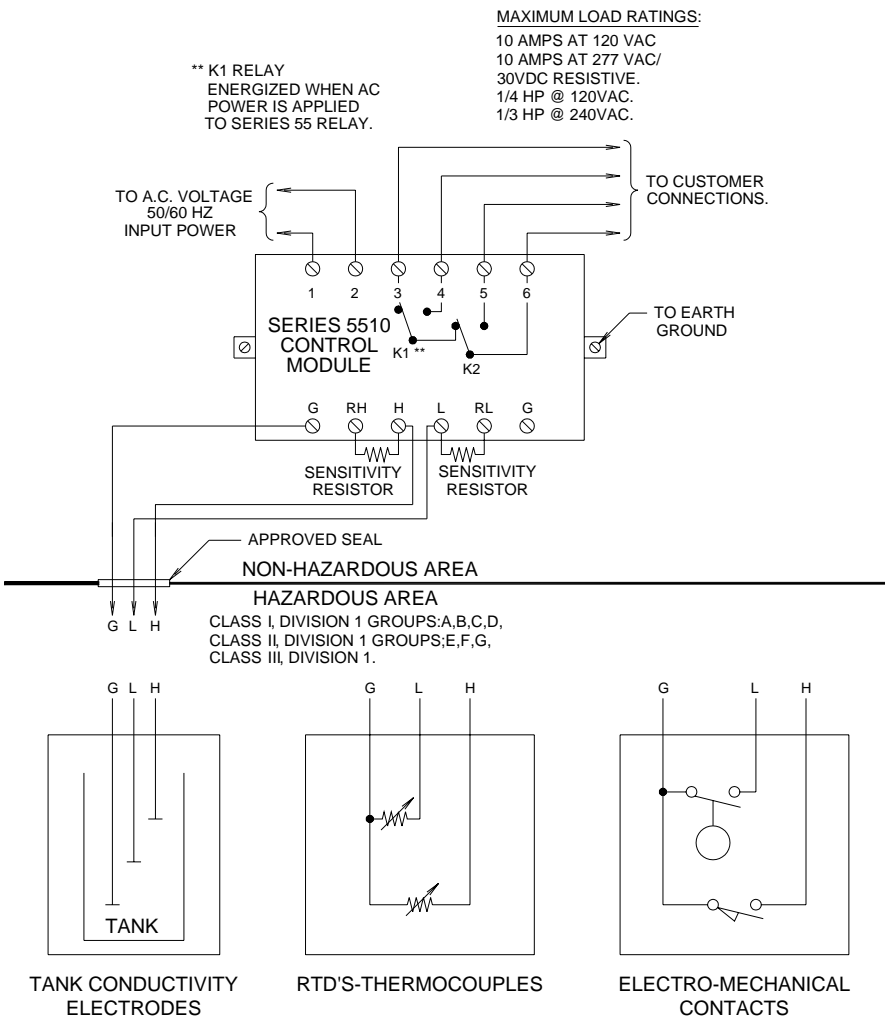

NOTES:

- BEFORE PROCEEDING TO INSTALL AND WIRE THE CONTROL MODULE, READ AND THOROUGHLY UNDERSTAND THESE INSTRUCTIONS. FOR ADDITIONAL GUIDANCE ON INTRINSICALLY SAFE SYSTEMS, REFER TO NATIONAL ELECTRIC CODE (ANSI/NFPA70) ARTICLE 504.
- THE CONTROL MODULE MUST BE EITHER SITUATED IN A NON-HAZARDOUS AREA OR MOUNTED INSIDE A SUITABLE APPROVED EXPLOSION PROOF ENCLOSURE.
- INTRINSICALLY SAFE WIRING MUST BE KEPT SEPARATE FROM NON-INTRINSICALLY SAFE WIRING.
- THE CIRCUIT WIRING IN THE HAZARDOUS AREA SHOULD NOT EXCEED 3000 FEET. THIS DISTANCE LIMITATION IS BASED ON A CABLE WITH A SPECIFIC CAPACITANCE OF 60 pF/FT AND A SPECIFIC INDUCTANCE OF 0.2 uH/FT.
- AN APPROVED SEAL SHOULD BE USED AT THE POINT WHERE THE INTRINSICALLY SAFE CONTROL CIRCUIT WIRING ENTERS THE HAZARDOUS AREA.
- ONLY ONE 'G' WIRE IS REQUIRED IN THE HAZARDOUS AREA. (INTRINSICALLY SAFE 'G' TERMINALS ARE ELECTRONICALLY CONNECTED TOGETHER IN THE CONTROL MODULE)
- INTRINSICALLY SAFE CONNECTIONS MUST ONLY BE MADE TO NON-ENERGY GENERATING OR STORING DEVICES SUCH AS SWITCH CONTACTS, NON-INDUCTIVE RESISTANCE TEMPERATURE DEVICES (RTD'S) AND THERMOCOUPLES, OR ANY TANK CONDUCTIVITY ELECTRODE.
- THE RESISTANCE BETWEEN THE GROUNDING TAB ON THE CONTROL MODULE AND EARTH GROUND MUST BE LESS THAN ONE (1.0) OHM.
- ELECTRICAL EQUIPMENT CONNECTED TO THE ASSOCIATED APPARATUS MUST NOT USE OR GENERATE MORE THAN 250 Vrms WITH RESPECT TO EARTH GROUND.
- SELECT SENSITIVITY RESISTORS TO SET OPERATING POINT OF RESISTIVE INPUTS (SEE CHART IN SERVICE BULLETIN). SET TO ZERO OHMS (JUMPER) FOR SWITCH CONTACT SENSING.

APPLICATIONS USING LIQUID LEVEL ELECTRODES

