

## TYPE WHT500 UTILITY WELL HOUSE HEATER

- Install it anywhere heat is needed to prevent pipes, pumps and other water, hydraulic fluid or oil-filled equipment from freezing.
- It is designed to provide automatic, 24-hour protection. Set the thermostat at any desired level and leave it. There are no moving parts. It is maintenance free and can be left unattended all winter long - ideal for remote locations.
- A steel sheath, aluminum finned element provides fast heat dissipation and a long life because of cooler sheath temperatures.
- The heater's cabinet encloses the element and consists of epoxy painted galvanized steel for corrosion protection.
- The thermostat is completely contained within the control box. 40° to 70° F.
- One model is adaptable to 120V or 240/208V supply. Shipped wired for 240/208V, field conversion to 120V is quick and easy.
- All power supply and control wiring terminates in the tamperproof control box - no live voltage in the element area.

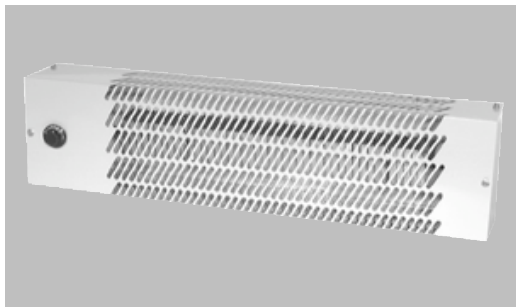
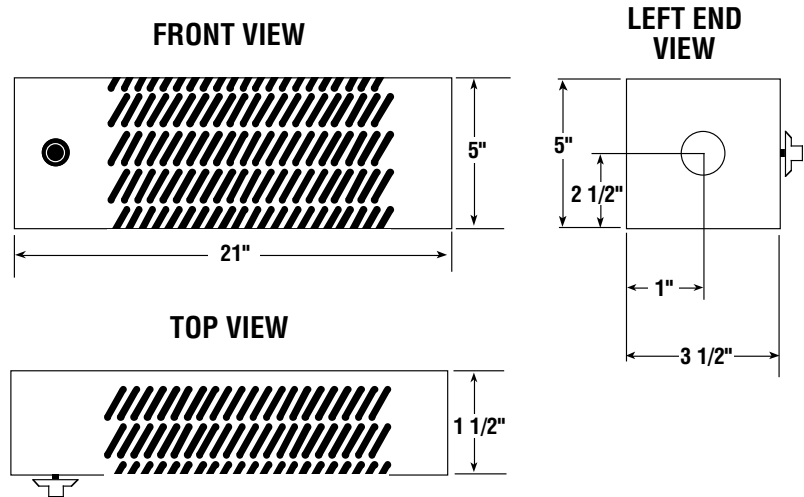

### SELECTION CHART

CATALOG NO.	VOLTS	WATTS	BTU/HR	AMPS
WHT500	120	500	1708	4.2
	240*	500	1708	2.1
	208	375	1284	1.8

\* As shipped. Can be field rewired for 120V.