

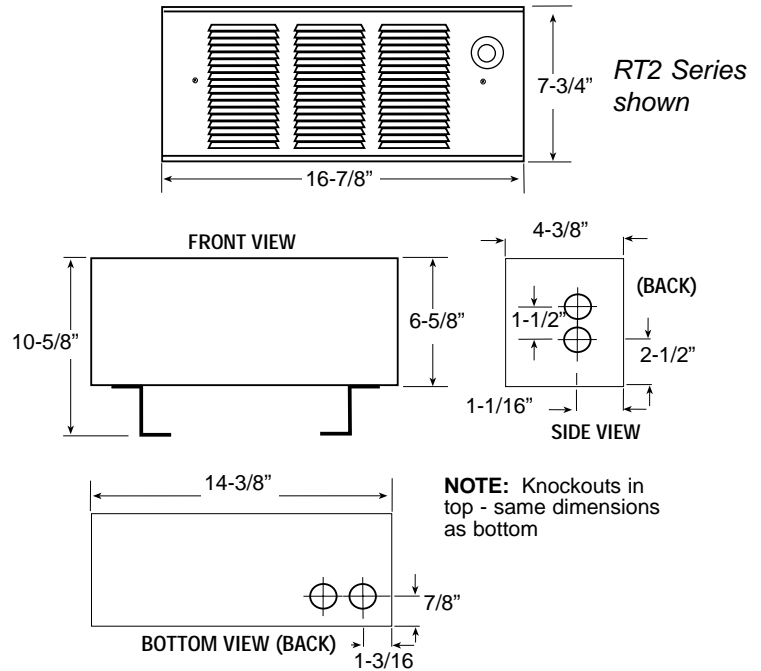

Marley
Engineered Products



**R Series &
RT2 Series
Fan Forced Wall Heaters**
with new Clip 'n' Fit[®] Board
US Patent No. 6,172,343



Installation & Maintenance Instructions

Dear Owner,

Congratulations! Thank you for purchasing this new heater manufactured by a division of Marley Engineered Products. You have made a wise investment selecting the highest quality product in the heating industry. Please carefully read the installation and maintenance instructions shown in this manual. You should enjoy years of efficient heating comfort with this product from Marley Engineered Products... the industry's leader in design, manufacturing, quality and service.

... The Employees of Marley Engineered Products



WARNING



Read Carefully - These instructions are written to help you prevent difficulties that might arise during installation of heaters. Studying the instructions first may save you considerable time and money later. Observe the following procedures, and cut your installation time to a minimum.
CAUTION - TO REDUCE RISK OF FIRE AND ELECTRIC SHOCK:

1. Disconnect all power coming to heater at main service panel before wiring or servicing.
2. All wiring must be in accordance with the National and Local Electrical Codes and the heater must be grounded.
3. Verify the power supply voltage coming to heater matches the ratings printed on the heater nameplate before energizing.
4. This heater is hot when in use. To avoid burns, do not let bare skin touch hot surfaces.
5. Do not insert or allow foreign objects to enter any ventilation or exhaust opening as this may cause an electric shock, fire, or damage to the heater.
6. Do not block air intakes or exhaust in any manner. Keep combustible materials, such as crates, drapes, etc., away from heater. Do not install behind doors, furniture, towels, or boxes.
7. A heater has hot and arcing or sparking parts inside. Do not use it in areas where gasoline, paint, or flammable liquids are used or stored.
8. Use this heater only as described in this manual. Any other use not recommended by the manufacturer may cause fire, electric shock, or injury to persons.
9. This heater is not approved for use in corrosive atmospheres such as marine, green house, or chemical storage areas.
10. Heater must only be installed in a horizontal direction (motor & thermostat to right) as shown in this manual. Do not install sideways or upside down.
11. Heater must be installed with Back Box.
12. For wall mounting only. The following minimum clearances must be maintained: Heater to floor - 4 in. (102 mm); Heater to any adjacent wall - 6 in. (152 mm); heater to ceiling - 36 in. (915 mm).
13. When wiring, power supply must enter through knockouts in right end of heater. Do not use the knockouts in left end of heater.
14. Do not operate heater without grille installed.
15. Do not use heater for dry out. Paint, plaster, sawdust and dry-wall sanding dust will damage heater and must be kept out of heater.
16. Grille and discharge air are hot when in use. Do not install or use heater in any area where the airflow from heater may be obstructed. Hot air may damage certain fabrics and plastics. Always keep electrical cords, bedding, furniture, and other combustibles away from heater.

SAVE THESE INSTRUCTIONS

The "R" Series heaters are designed for recessed installation in standard 2 x 4 (50mm X 100mm) or larger stud walls with the back box mounted as shown in either Fig. 1, or Fig. 2.

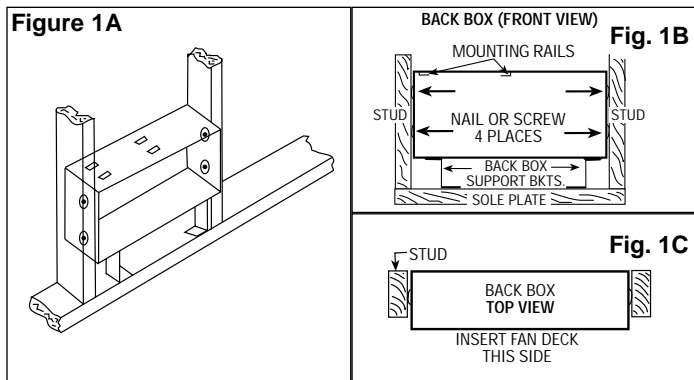

NOTE: Heater should be controlled by either built-in thermostat or remote wall thermostat. Models with "T2" suffix are equipped with built-in thermostat.

This heater may be wired with standard building wiring (rated minimum 60° C). Refer to Table 2 (Page 3) for appropriate wire size for the heater to be used.

NOTE TO INSTALLER

The "IF" models do not include a backbox. The Backbox is ordered separately. In the parts bag for "IF" models, there is a white label that indicates multiple wattage and must be placed in the backbox on the bottom right-hand side. When making wattage changes, the installer must circle the wattage on the white label before installing the heat deck.

TO INSTALL BACK BOX (Model RBB) IN NEW CONSTRUCTION - WALL STUDS 16" OC. (REFER TO FIG. 1)

1. Locate back box (model RBB) and back box support brackets (2). Back box must be installed with mounting rails to the top (see Fig. 1B).
2. Install back box support brackets with foot tabs directed towards the center of the back box as shown in Fig. 1A and 1B.
3. Determine which knockout in back box will be used for field wiring and remove (see back box drawing pg.1). Install strain relief (field supplied). See warning No. 13.
4. Fish field wiring through strain relief leaving 6" of wire inside box.
5. Insert back box assembly into wall, aligning rear of back box with back side of studs (see Fig. 1C). The back box support brackets should be resting on the sole plate of the stud wall to insure proper spacing and leveling (see Fig. 1B).
6. Using four (4) wood screws or drywall screws or four (4) nails (field supplied), secure back box to studs (see Fig. 1B). Back box support brackets can now be removed. If not removed, secure to sole plate.

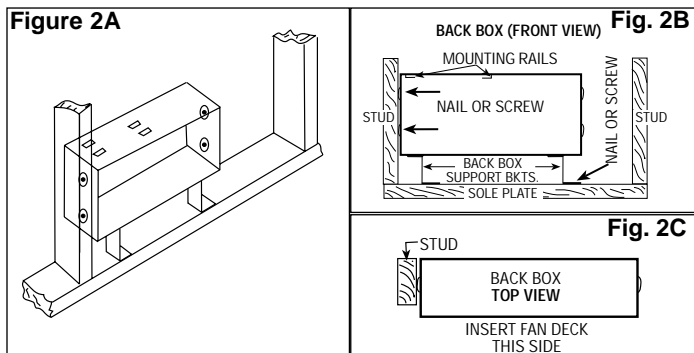

TO INSTALL BACK BOX IN NEW CONSTRUCTION - WALL STUDS SPACING GREATER THAN 16" OC. (REFER TO FIG. 2)

NOTE: Fig. 2 depicts the back box installed with the left side adjoining stud. For a box with the right side adjoining a stud, reverse the directions shown below.

1. Locate back box and back box support brackets (2). Back box must be installed with mounting rails to the top (see Fig. 2B)
2. Determine which side of the back box will adjoin stud and insert back box support bracket on that side with foot tab directed towards center of back box. On the side of the back box that will not adjoin stud, install back box support bracket on that side with foot tab directed towards end of box and secure to box with 3/8" long sheet metal screw (provided).
3. Determine which knockout in back box will be used for field wiring and remove (see back box drawing pg. 1). Install strain relief (field supplied).
4. Fish field wiring through strain relief leaving 6" of wire inside box.
5. Insert back box assembly into wall, aligning rear of back box with back side of stud (see Fig. 2C). The back box support brackets should be resting on the sole plate of the stud wall to insure proper spacing and leveling (see Fig. 2B).
6. Use two (2) wood screws or drywall screws or two (2) nails (field supplied) to secure the side of the back box that adjoins a stud. Use one (1) wood screw or drywall screw or one (1) nail (field supplied) to secure the foot tab of the back box support bracket (that is on the end opposite the stud) to the sole plate (see Fig. 2B).

Figure 3

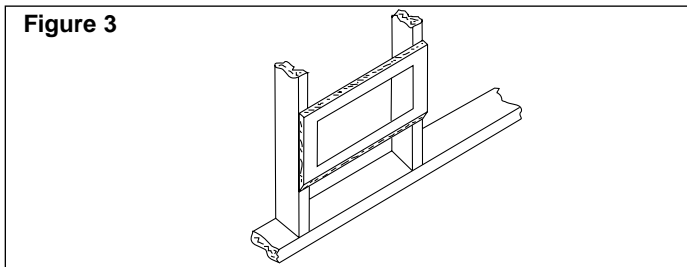

TO INSTALL BACK BOX IN EXISTING CONSTRUCTION

1. Locate wall studs to be sure that entire cut-out can be made between studs. At least one side of the cut-out must be flush with side of the stud. Bottom of cut-out must be 4" above finished floor minimum. Make a cut-out in wall 14-1/2" wide X 6-3/4" high (368mm X 171mm) (see Fig. 3).
2. Determine which knockout in back box will be used for field wiring and remove (see back box drawing, pg.1). Install strain relief (field supplied).
3. Fish field wiring through strain relief leaving 6" of wire inside box.
4. Insert back box into cut-out. Rear of back box should be flush with back of stud wall.
5. Using four (4) wood screws or drywall screws (field supplied) or four (4) nails (field supplied), secure back box to studs (see Fig. 1B). If wall studs are greater than 16"oc., use only 2 fasteners and on the opposite end of the back box drive a 1" sheet metal screw (provided) through hole in end cap. This will draw the back box tight with drywall when grille is installed. (See Fig. 4.)

TO INSTALL THERMOSTAT ASSEMBLY (RT2 only)

NOTE: Thermostat assembly should not be installed until after the drywall phase of construction is complete. Dust from drywall installation and joint compound can be harmful if it gets inside thermostat assembly components.

1. The thermostat must be installed in right end of the heater.
2. Position thermostat above slot in right end of back box. Push tab on thermostat bracket through slot in top, right end of back box until the bracket locks in place. See Fig. 5.

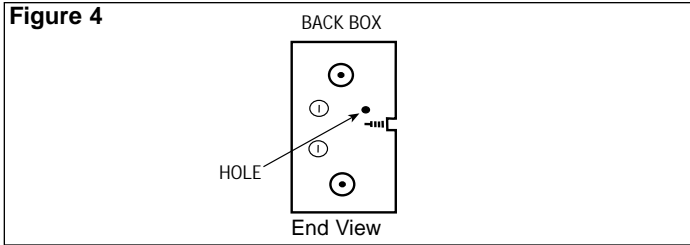

- If the thermostat is controlling more than one heater, the total of all heater amperage ratings (Table 1) cannot exceed 25 amps at 120 volts AC thru 240 volts AC. Refer to Table 2 for correct wire, circuit breaker, or fuse sizing.
- Connect one red and one black thermostat lead to power wiring per wiring diagram (Fig. 6) using properly sized listed wirenuts (provided).
- Fold wires back into wiring compartment behind thermostat to clear fan deck.

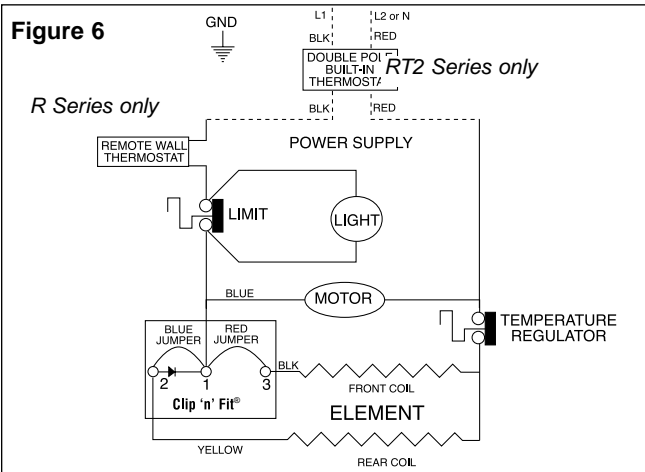
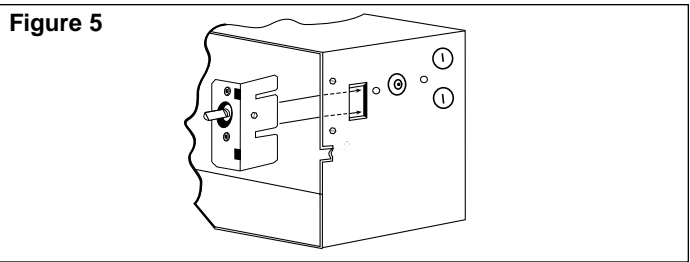

TO INSTALL FAN DECK ASSEMBLY

NOTE: Fan deck assembly should not be installed until after the drywall phase of construction is complete. Dust from drywall installation and joint compound can be harmful if it gets inside fan deck components.

- Locate fan deck and mounting rails in top of back box.
- Insert flanges on fan deck into mounting rails and slide back until fan deck stops (see Fig. 7).
- Make wiring connections, attaching one red and one black thermostat lead to two (2) black heater leads for 240V or to black and white heater leads for 120V with wirenuts (provided). Connect field ground lead to bare ground wire with wirenut (provided). See Fig. 6.
- Remove 1/2" knockout from grille and install grille using two oval head screws. Push thermostat knob on thermostat shaft.
- Reconnect power at main fuse or circuit breaker distribution panel.

TO CHANGE WATTAGE OUTPUT

The chart shows the wattages available by model. Each heater is factory wired for its maximum wattage. The last two columns in the chart refer to the jumpers on the CLIP 'n' Fit® Board. To change wattage, clip out Jumper 1 and/or Jumper 2 as shown in the chart below. Completely remove jumpers by clipping at both ends as close to the board as possible.

WATTAGE					JUMPER 1	JUMPER 2
R2404 & R2404T2	R2004 & R2004T2	R1500 & R1500T2			Blue Jumper	Red Jumper
@240V	@208V	@240V	@208V	@120V		
2400	1800	2000	1500	1500	Leave in	Leave in
1800	1350	1500	1125	1125	Clip out	Leave in
1200	900	1000	750	750	Leave in	Clip out
600	450	500	375	375	Clip out	Clip out

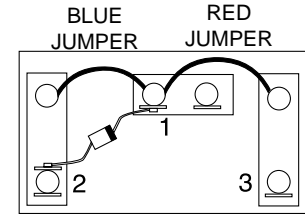

Clip 'n' Fit® Board

TABLE 1

MODEL	VOLTS	WATTS/AMPS	WATTS/AMPS	WATTS/AMPS	WATTS/AMPS
R1500 R1500T2	120	1500W/12.5A	1125W/9.4A	750W/6.3A	375W/3.1A
R2004 R2004T2	240	2000W/8.3A	1500W/6.3A	1000W/4.2A	500W/2.1A
	208	1500W/7.2A	1125W/5.4A	750W/3.6A	375W/1.8A
R2404 R2404T2	240	2400W/10.0A	1800W/7.5A	1200W/5.0A	600W/2.5A
	208	1800W/8.7A	1350W/6.5A	900W/4.3A	450W/2.2A

Note: "IF" Inner Frame models must be used with RBB Back box.

TABLE 2

TOTAL AMPS	WIRE SIZE (COPPER)	CIRCUIT BREAKER OR FUSE SIZE
0 thru 12	#14	15 Amps
12.1 thru 16	#12	20 Amps
16.1 thru 24	#10	30 Amps

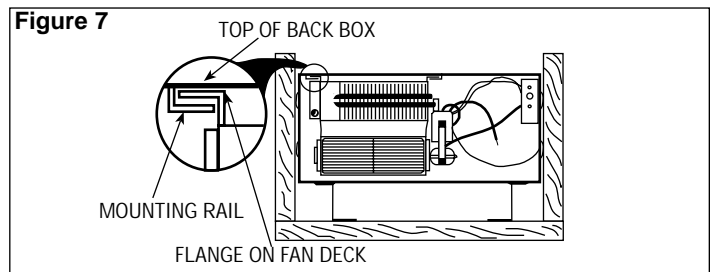

IMPORTANT INFORMATION

MAINTENANCE

TO CLEAN HEATER: The heater should be cleaned annually for maximum efficiency or more often if used in dirty environment. Before cleaning be sure power is off and heater is cool. First, remove knob by pulling straight out, then remove front grille and clean blower wheel using a vacuum cleaner with a brush attachment. The grille may be cleaned with a slightly damp rag if desired.

OPERATIONAL NOTICE

Your heater is equipped with an automatic reset limit control that will automatically turn the heater OFF to prevent a fire if the heater overheats. Should this occur, the red warning light will illuminate and will continue to shine until the limit resets.

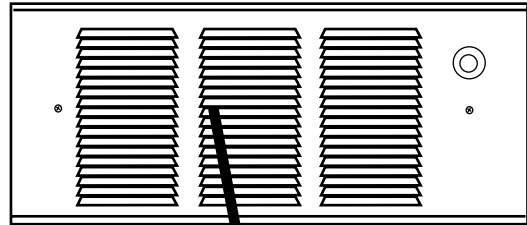

Model shown is
"RT2" series with
built-in thermostat.

CAUTION



THE ILLUMINATED RED WARNING LIGHT SIGNIFIES THE HEATER HAS BEEN SUBJECTED TO SOME ABNORMAL CONDITION CAUSING IT TO OVERHEAT. CHECK HEATER TO INSURE THAT IT HAS NOT BEEN BLOCKED IN ANY MANNER (IF SO, REMOVE BLOCKAGE). IF THERE IS NO INDICATION OF BLOCKAGE IT IS RECOMMENDED THE HEATER BE CHECKED BY A REPUTABLE ELECTRICIAN OR REPAIR SERVICE TO INSURE THE HEATER HAS NOT BEEN DAMAGED. DO NOT CONTINUE TO USE HEATER IF LIGHT IS ON.

NAMEPLATE

MODEL NO. **R1500T2** DATE CODE **0599**

FAN FORCED WALL HEATER

120 VOLTS AC 1500/1125/750/375 WATTS 12.5/9.4/6.3/3.1 AMPS

USE ONLY WITH RBB SERIES BACK BOX. DO NOT OPERATE WITHOUT GRILLE IN PLACE.



774G LISTED
ROOM HEATER

MARLEY ENGINEERED PRODUCTS
BENNETTSTVILLE, SC 29512

4104-2159-003

LIMITED WARRANTY

All products manufactured by Marley Engineered Products are warranted against defects in workmanship and materials for one year from date of installation, except heating elements which are warranted against defects in workmanship and materials for five years from date of installation. This warranty does not apply to damage from accident, misuse, or alteration; nor where the connected voltage is more than 5% above the nameplate voltage; nor to equipment improperly installed or wired or maintained in violation of the product's installation instructions. All claims for warranty work must be accompanied by proof of the date of installation.

The customer shall be responsible for all costs incurred in the removal or reinstallation of products, including labor costs, and shipping costs incurred to return products to Marley Engineered Products Service Center. Within the limitations of this warranty, inoperative units should be returned to the nearest Marley authorized service center or the Marley Engineered Products Service Center, and we will repair or replace, at our option, at no charge to you with return freight paid by Marley. It is agreed that such repair or replacement is the exclusive remedy available from Marley Engineered Products.

THE ABOVE WARRANTIES ARE IN LIEU OF ALL OTHER WARRANTIES EXPRESSED OR IMPLIED AND ALL IMPLIED WARRANTIES OF MERCHANTABILITY AND FITNESS FOR A PARTICULAR PURPOSE WHICH EXCEED THE AFORESAID EXPRESSED WARRANTIES ARE HEREBY DISCLAIMED AND EXCLUDED FROM THIS AGREEMENT. MARLEY ENGINEERED PRODUCTS SHALL NOT BE LIABLE FOR CONSEQUENTIAL DAMAGES ARISING WITH RESPECT TO THE PRODUCT, WHETHER BASED UPON NEGLIGENCE, TORT, STRICT LIABILITY, OR CONTRACT.

Some states do not allow the exclusion or limitation of incidental or consequential damages, so the above exclusion or limitation may not apply to you. This warranty gives you specific legal rights, and you may also have other rights which vary from state to state.

For the address of your nearest authorized service center, contact Marley Engineered Products in Bennettsville, SC, at 1-800-642-4328. Merchandise returned to the factory must be accompanied by a return authorization and service identification tag, both available from Marley Engineered Products. When requesting return authorization, include all catalog numbers shown on the products.

HOW TO ORDER REPAIR PARTS

In order to obtain any needed repair or replacement parts, warranty service or technical information, please contact Marley Engineered Products Service Center toll-free by calling 1-800-642-HEAT.

When ordering repair parts, always give the information listed as follows:

1. The Model Number
2. The Part Description
3. Date of Manufacture



Marley
Engineered Products
An **SPX** Company

470 Beauty Spot Rd. East
Bennettsville, SC 29512 USA

ECR 35050

5200-2367-004

01/02

4