

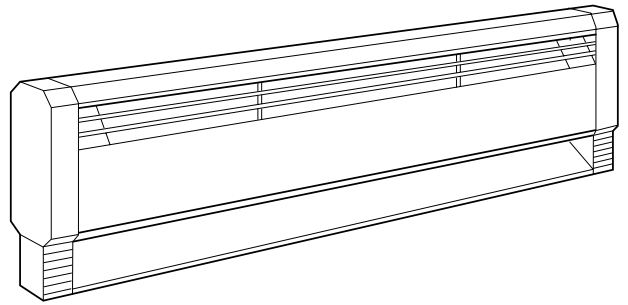

Marley
Engineered Products



D Series

Commercial Baseboard Heater



Installation & Maintenance Instructions

Dear Owner,

Congratulations! Thank you for purchasing this new heater manufactured by a division of Marley Engineered Products. You have made a wise investment selecting the highest quality product in the heating industry. Please carefully read and follow the installation and maintenance directions shown in this manual. You should enjoy years of efficient heating comfort with this product from Marley Engineered Products... the industry's leader in design, manufacturing, quality and service.

*... The Employees of
Marley Engineered Products*

WARNING

Read Carefully - This instruction sheet contains vital information for the proper installation, use and efficient operation of the heater. Carefully read the manual before installation, operation, or cleaning of the heater. Failure to adhere to the instructions could result in fire, electric shock, death, serious personal injury or property damage. Save these instructions and review frequently for continuing safe operation and instructing future users.

WARNING: HAZARD OF FIRE OR ELECTRICAL SHOCK.

1. Keep all electrical cords, foam filled articles, drapes, bedding and other household furnishings away from contact with heater. It is recommended all items be kept a minimum of six (6") inches (152mm) from heater.
2. Do not install baseboard heater below electrical convenience receptacles (outlets).
3. Do not install baseboard heater against vinyl wallpaper, paperboard or low density fiberboard surface.

4. Do not install vinyl drapes or vinyl blinds above heater.
5. Do not recess heater in wall.
6. The installation must comply with applicable local, and National Electrical Code and utility requirements.
7. Do not remove or by-pass thermal cutout.
8. To reduce the risk of fire, do not store or use gasoline or other flammable vapors and liquids in the vicinity of the heater.
9. Personal injury or death could result from electric shock. Disconnect all power to heater at main panel before attempting to install or service this heater.
10. Supply voltage must be the same as heater voltage. Check heater nameplate and supply voltage before energizing.
11. Supply wiring must be suitable for 90°C.
12. Risk of fire - Do not make connections in raceway.

SAVE THESE INSTRUCTIONS

IMPORTANT

CAUTION

CERTAIN FABRICS DISCOLOR IN TIME FROM INDIRECT SUNLIGHT AND NORMAL ROOM TEMPERATURE - MOSTLY ORGANIC AND SYNTHETIC MATERIAL. THEY WILL DISCOLOR MORE RAPIDLY WHEN EXPOSED TO DIRECT SUNLIGHT AND WARM CURRENTS. HANG DRAPES TO PROVIDE MINIMUM OF 2 INCHES (51mm) AIR SPACE BETWEEN HEATER FRONT AND NEAREST DRAPE FOLD AS SHOWN IN EXAMPLE 1, FIGURE 1, OR 6 INCHES (152mm) AIR SPACE BETWEEN TOP OF HEATER AND BOTTOM OF DRAPES AS SHOWN IN EXAMPLE 2, FIGURE 1. ALLOW MINIMUM CLEARANCE OF 1 INCH (25mm) FROM DRAPES TO CEILING AND TO TOP OF FLOOR COVERING TO PERMIT AIR CIRCULATION.

CLEARANCES

FLOORS & CARPETING: HEATERS MAY BE MOUNTED DIRECTLY ON ANY FLOOR SURFACE, INCLUDING CARPETING. WHERE WALL-TO-WALL CARPETS ARE INSTALLED AFTER THE BASEBOARD INSTALLATION, THE CARPETING CAN BE RUN UP TO THE FRONT AND AROUND THE HEATER BODY.

FULL LENGTH DRAPES: FOR THE MOST SATISFACTORY OPERATION OF HEATERS, THE FOLLOWING CLEARANCES MUST BE MAINTAINED:

1. HANG DRAPES SO THAT, IN USE, THEY EXTEND BELOW THE CENTER LINE OF THE HEATER, BUT WITH AT LEAST 1" (25mm) CLEARANCE FROM THE TOP OF THE FINISHED FLOOR COVERING, SUCH AS CARPET, TILE, ETC.
2. HANG DRAPES SO THERE IS AT LEAST 2" (51mm) BETWEEN THE EXTREME FRONT OF THE HEATER AND THE NEAREST FOLD OF DRAPES, IN THE FOLDED BACK POSITION (OPEN DRAPE POSITION).
3. HANG DRAPES SO THERE IS AT LEAST 1" (25mm) BETWEEN THE TOP OF THE DRAPES AND THE CEILING.

SHORT DRAPES: HANG DRAPES SO THERE IS AT LEAST 6" (152mm) CLEARANCE ABOVE THE TOP OF THE HEATER.

FURNITURE: DO NOT PLACE FURNITURE AGAINST HEATER. IT IS RECOMMENDED ALL ITEMS BE KEPT A MINIMUM OF 6" (152mm) INCHES FROM HEATER.

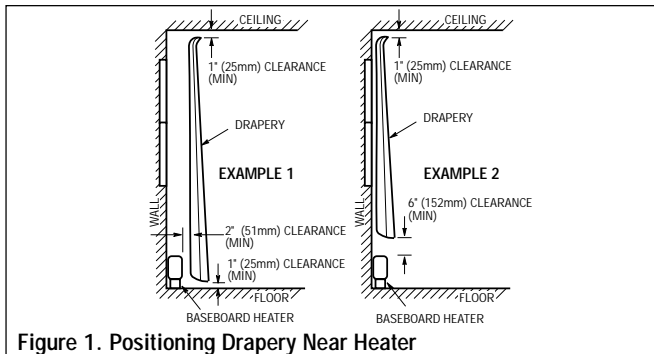

Figure 1. Positioning Drapery Near Heater

INSTALLATION OF SINGLE UNIT

Commercial baseboard heaters are designed for installation in new or existing construction. In existing construction, baseboard molding should be removed and the heaters mounted flush against the wall surface. When replacing molding allow 1/16" (1 mm) clearance between molding and ends of heaters.

NOTE: This heater can be wired in either the right or left hand junction box. See Table 1 for wiring compartment volumes.

CAUTION

HEATER MAY BE INSTALLED ABOVE THE FLOOR SUCH AS ATOP A BASEBOARD. HOWEVER, THE POWER SUPPLY MUST ENTER THE HEATER THROUGH THE KNOCKOUT IN THE BACK OF THE HEATER OR RACEWAY COVER IF INSTALLED ABOVE THE FLOOR.

CAUTION

TO PREVENT POSSIBLE DAMAGE TO INTERNAL HEATER WIRING, ALL DRILLING OF END CAPS MUST BE DONE WITH END CAPS REMOVED FROM HEATER.

Table 1. Field Wiring Compartment Volumes

Description	Est. Net Total Volume	
	CM ³	In ³
Heater Wiring Compartment (One End)	200	13.25
Heater Wiring Compartment with T1 or T2 Thermostat Accessory	175	11.25
Accessory Blank Section (No Controls)	2400	145
AC Accessory Section	2300	140
DR Accessory Section	2300	140
CDS2 Accessory Section	2300	140
LVR Accessory Section	2100	130

1. Position the heater at the desired location on the wall as shown in Figure 2. For maximum heating comfort, position the heater under a window.

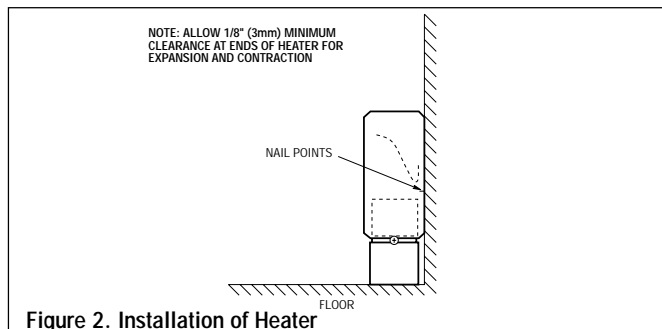

Figure 2. Installation of Heater

2. Mark the location on the wall or floor for the power supply entry into the heater. Remove the heater from the wall and drill appropriate hole in the wall or floor.
3. Remove the left or right junction box end cap by removing the screw in the end of the heater and sliding the cap outward from the heater (Figure 3).

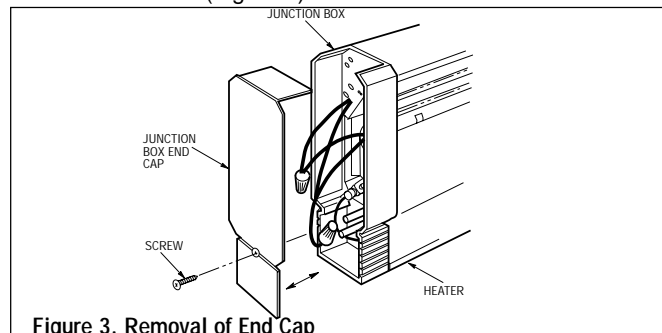

Figure 3. Removal of End Cap

4. Remove the front cover of the heater by removing the screws in the lower corners. Pull the bottom of the cover outward and lift the top of the cover off the junction box. Repeat for the opposite end. Snap the top of the cover off the center bracket and off the intermediate supports. See Figure 4.

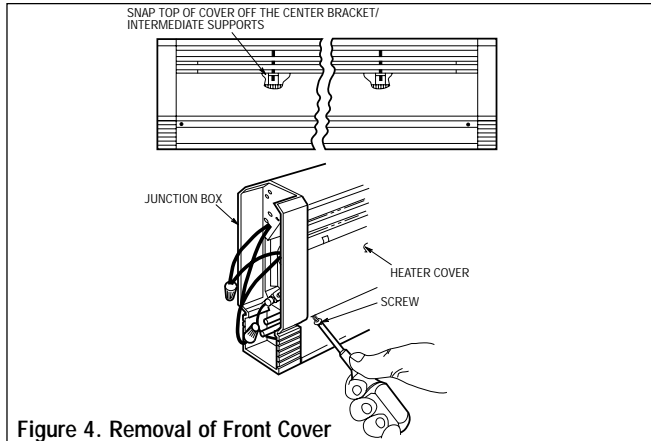

Figure 4. Removal of Front Cover

5. If wires are to enter or pass through raceway, remove raceway cover and remove the appropriate electrical knockout from the back of the heater or raceway as necessary.
6. If one or more heaters are connected to a single branch circuit, determine the total amperage load (see Specifications Table on page 4), then determine the power supply wire size and the circuit breaker or fuse size required (See Table 2).

Table 2.

Total Amps	Minimum AWG Wire Size (Copper)	Circuit Breaker or Fuse Size
0 thru 12	#14	15 Amp
12.1 thru 16	#12	20 Amp
16.1 thru 24	#10	30 Amp

7. Bring power supply wire to the heater and thermostat locations as determined by the thermostat option selected.

IF POWER SUPPLY IS TO ENTER HEATER THROUGH KNOCKOUT IN BACK OF HEATER, install wire using cable clamp leaving 6 to 8-inches (152 to 203mm) of wire inside heater for connections.

IF POWER SUPPLY ENTERS HEATER THROUGH RACEWAY, install wire using cable clamp at the knockout in the raceway, and feed the wire into the junction box leaving 6 to 8-inches (152 to 203mm) of wire inside junction box for connections. DO NOT make connections in raceway.

NOTE: No clamp is required where the cable passes through the hole in the plastic junction box.

8. Position the heater on the wall and locate wall studs. Drill or punch holes through the enclosure back (above the element) at stud locations.

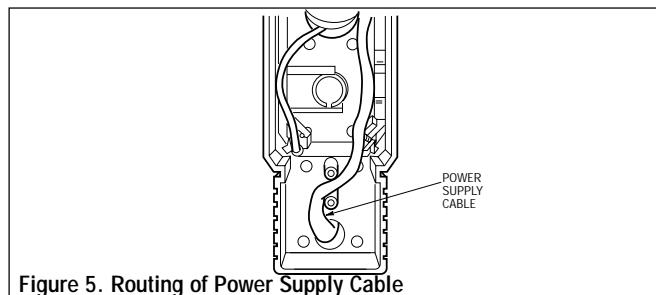

Figure 5. Routing of Power Supply Cable

NOTE: The heater enclosure is provided with nail point marks showing correct locations for mounting holes.

The following methods of mounting the heaters to common types of wall surfaces are suggested:

- a. **Plaster Walls:** Use toggle or molly screw anchors.
- b. **Wall Studs:** Use #12 round head screws penetrating at least 3/4" (19mm) into stud.
- c. **Masonry Walls:** Use #12 round head screws into lead, plastic, or fiber expansion anchor.

Tighten all screws snugly, then back off 1/2-turn to allow the back panel to expand and contract.

9. Connect supply wiring to heater as described in Figure 6, or as shown in the wiring diagrams supplied with the accessory kits intended for use with this heater.
10. Secure the desired accessories to baseboard as shown in the accessory instruction sheet, and use the wiring diagram supplied with the accessory.

NOTE: Baseboard heaters must be thermostatically controlled.

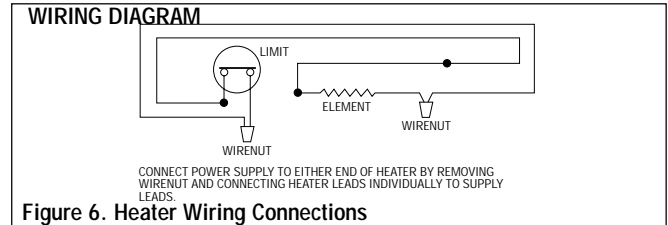

Figure 6. Heater Wiring Connections

11. Replace the front cover by fitting the top lip of the cover onto the tabs on each junction box and top edge of the element support bracket(s). Rotate the cover downward, pushing the bottom corners inward. Install two screws (removed in Step 4) through the cover into the junction boxes. See that the bottom of the cover is engaged onto the bottom of each element support bracket. See Figure 7.

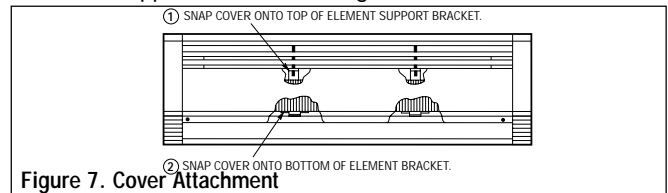

Figure 7. Cover Attachment

12. Replace the end cap(s) by installing screw(s) (removed in Step 3).

INSTALLATION OF MULTIPLE UNITS

1. With heaters mounted end-to-end, allow 1/32-inch (1mm) of expansion space per heater between each heater.
2. For each heater to be installed, refer to and follow "Installation of Single Unit", Steps 1 through 7.
3. If the power supply is to enter through the end of the heater series so that the end cap can be installed after the heaters are installed, continue "Installation of Single Unit", Steps 8 through 11.
4. If the power supply is to feed heaters at the junction box that is adjacent to another heater, it is easier for the power supply connections to be made prior to the installation of the heater(s) to the wall. If this is not possible, connections may be made through the opening in the junction boxes when the front cover(s) is removed. See Figure 8.

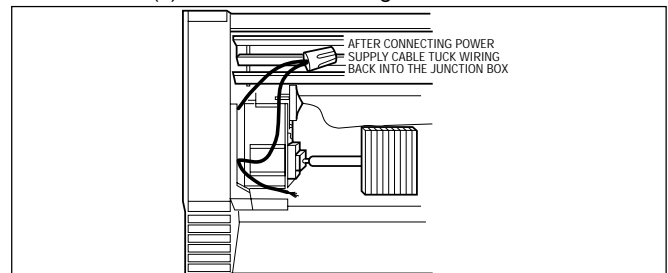

Figure 8. Wiring Through Junction Box Opening

5. Connecting power supply cables may be routed from heater to heater by drilling a 1/2-inch (13mm) diameter hole in the end caps for the heaters that fit together. See Figure 9. To prevent possible damage to internal heater wiring, all drilling of end caps must be done with end caps removed from heater.
6. Wire heaters as shown in Wiring Diagram, Figure 10.

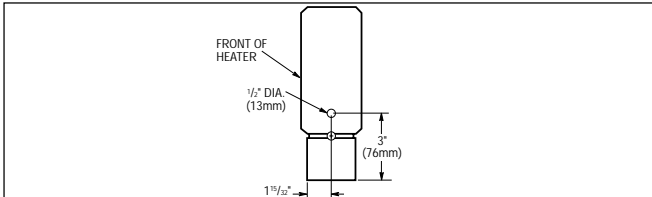

Figure 9. End Cap Drill Pattern

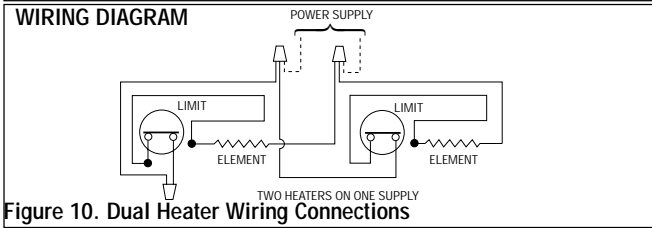

Figure 10. Dual Heater Wiring Connections

7. Replace the front covers and end caps according to "Installation of Single Unit", Steps 11 and 12.

OPERATING AND MAINTENANCE INSTRUCTIONS

1. An integral or remote wall thermostat is recommended for each room. In very large rooms it is recommended that a low voltage thermostat with double or multiple circuit relays be used to provide the most comfortable results.

DO LOCATE THERMOSTAT

- A minimum of two feet (61cm) from any outside wall.
- Approximately five feet (1.5m) from the floor, preferably on an inside wall location.

DO NOT LOCATE THERMOSTAT

- Near televisions or appliances that emit heat.
- Near drafts from an open doorway.
- Where it would be struck by direct rays of sunlight.

2. After the baseboard system has been completely installed, all thermostats should be turned to LOW or NO HEAT setting. Then turn on breakers or install fuses. Wait 3 to 5 minutes and check to see that none of the heaters are operating. If operating, disconnect power and check wiring. If none are operating then turn the thermostats to highest setting and wait 3 to 5 minutes. Check to see that all heaters are operating. Should any not be operating, disconnect power and check wiring.
3. Allow entire system to operate steadily for 1/2-hour. For a period of time after the heaters are put into operation, the owner may notice a "new smell" coming from the heaters. This is expected on new installations. Bringing heaters to full operation will eliminate this condition in a short period of time.
4. Select the setting for comfort on all thermostats.

5. **To clean heater:** Because of the convection heating principle which depends upon circulation of air through the finned element, dust particles will periodically be deposited between the fins and should be removed occasionally for maximum efficiency of the heater. A vacuum cleaner with proper attachments can easily be worked along the top and bottom of the finned element to clear it of dust deposits.

NOTE: The painted finish of the heater may be cleaned with a slightly damp cloth if desired. Do not use wax cleaners or polishes as these waxes may vaporize when the heater is in operation and cause discoloration.

HOW TO ORDER REPAIR PARTS

In order to obtain any needed repair or replacement parts, warranty service or technical information, please contact Marley Engineered Products Service Center toll-free by calling 1-800-642-HEAT.

When ordering repair parts, always give the information listed as follows:

1. The Part Number
2. The Model Number
3. The Part Description
4. Date of Manufacture



SPX Corporation
470 Beauty Spot Rd. East
Bennettsville, SC 29512 USA

IMPORTANT INFORMATION SPECIFICATIONS

Model	Volts	Watts	Amps	Length
D500	120	500	4.17	28" (71.1cm)
D508	208	500	2.40	
D504	240	500	2.08	
D507	277	500	1.81	
D750	120	750	6.25	34" (86.4cm)
D758	208	750	3.61	
D754	240	750	3.13	
D757	277	750	2.71	
D1000	120	1000	8.33	46" (1.17m)
D1008	208	1000	4.81	
D1004	240	1000	4.17	
D1007	277	1000	3.61	
D1250	120	1250	10.42	58" (1.47m)
D1258	208	1250	6.01	
D1254	240	1250	5.21	
D1257	277	1250	4.51	
D1500	120	1500	12.50	70" (1.78m)
D1508	208	1500	7.21	
D1504	240	1500	6.25	
D1507	277	1500	5.42	
D2008	208	2000	9.62	94" (2.39m)
D2004	240	2000	8.33	
D2007	277	2000	7.22	

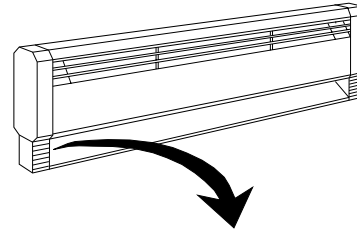

NAMEPLATE

MODEL NO. D1007	DATE
CODE 0195	
ELECTRIC BASEBOARD HEATER PLINTE CHAUFFANTE ELECTRIQUE	
	
VOLTS AC 277/240/208	WATTS 1000/750/565
AMPS 3.6/3.2/2.8	60HZ
MARLEY ENGINEERED PRODUCTS BENNETTSVILLE, SC 29512	
54E1 LISTED ELECTRIC BASEBOARD HEATER 4104-2022-275	

LIMITED WARRANTY

All products manufactured by Marley Engineered Products are warranted against defects in workmanship and materials for one year from date of installation, except heating elements which are warranted against defects in workmanship and materials for five years from date of installation. This warranty does not apply to damage from accident, misuse, or alteration; nor where the connected voltage is more than 5% above the nameplate voltage; nor to equipment improperly installed or wired or maintained in violation of the product's installation instructions. All claims for warranty work must be accompanied by proof of the date of installation.

The customer shall be responsible for all costs incurred in the removal or reinstallation of products, including labor costs, and shipping costs incurred to return products to Marley Engineered Products Service Center. Within the limitations of this warranty, inoperative units should be returned to the nearest Marley authorized service center or the Marley Engineered Products Service Center, and we will repair or replace, at our option, at no charge to you with return freight paid by Marley. It is agreed that such repair or replacement is the exclusive remedy available from Marley Engineered Products.

THE ABOVE WARRANTIES ARE IN LIEU OF ALL OTHER WARRANTIES EXPRESSED OR IMPLIED. AND ALL IMPLIED WARRANTIES OF MERCHANTABILITY AND FITNESS FOR A PARTICULAR PURPOSE WHICH EXCEED THE AFORESAID EXPRESSED WARRANTIES ARE HEREBY DISCLAIMED AND EXCLUDED FROM THIS AGREEMENT. MARLEY ENGINEERED PRODUCTS SHALL NOT BE LIABLE FOR CONSEQUENTIAL DAMAGES ARISING WITH RESPECT TO THE PRODUCT, WHETHER BASED UPON NEGLIGENCE, TORT, STRICT LIABILITY, OR CONTRACT.

Some states do not allow the exclusion or limitation of incidental or consequential damages, so the above exclusion or limitation may not apply to you. This warranty gives you specific legal rights, and you may also have other rights which vary from state to state.

For the address of your nearest authorized service center, contact Marley Engineered Products, in Bennettsville, SC, at 1-800-642-4328. Merchandise returned to the factory must be accompanied by a return authorization and service identification tag, both available from Marley Engineered Products. When requesting return authorization, include all catalog numbers shown on the products.