



# SERIES 08-03

## Precision Snap Disc Thermostats High Temperature Surface Mounting Type



8.11.9

### FEATURES

- Ratings to 10A at 240VAC
- 100,000 Cycle Rating
- UL Component Recognized 
- CSA Certified 
- CE Compliant 
- Automatic Reset
- Vibration Resistant
- Tamper-Proof Preset Temperature Calibrated Settings from 240 to 550°F/116 to 288°C

### APPLICATIONS

- Food Processing
- Ovens
- Packaging
- Copiers
- Plastic Processing

### DESCRIPTION

A positive-acting bimetal snap disc serves as the actuating element in these rugged, precision thermostats. As temperature reaches the tamper-proof predetermined set point, the disc snaps to provide rapid, positive contact action minimizing radio frequency interference.

These UL recognized thermostats are individually calibrated and tested to meet both thermal and electrical characteristics. The single contact switch arm assembly minimizes failures due to contact contamination, while the fine silver contacts assure long life and excellent current carrying capacity. Resistance to vibration and harsh environments are additional features.

Many terminations and mounting assemblies are available to permit great flexibility in installation.

Series 08-03 units are designed for high temperature applications up to 550°F/288°C. The ceramic base material and stainless steel cap provide excellent resistance to high temperature environments and keep the switch assembly free from dust and foreign particles.



### TEST SAMPLES

Operating samples can be supplied for application tests. A completed Fenwal Snap Disc Application Data Form is required to select and produce an operating sample. Application Data Forms are available from Fenwal or your local Fenwal sales representative.

# SPECIFICATIONS

## Switch Action

SPST (normally open or normally closed).

## Dielectric Strength

1500VAC terminals to case.

## Insulation Resistance

100 Megohms minimum at 500VDC.

## Vibration

MIL-STD-202D, Method 204B; 10 G's.

## Shock

MIL-STD-202D, Method 213A,  
Test Condition K, 30 G's, 11 millisec.

## RANGES AND TOLERANCES



**TABLE 1**



Temperature Ranges	Tolerances		Differential (Nominal)	Ambient Range
	Open	Close		
240 - 300 °F	± 7 °F	± 8 °F	25 °F	-50 to 600 °F -46 to 316 °C
116 - 148 °C	± 4 °C	± 4.5 °C	14 °C	
301 - 400 °F	± 10 °F	± 15 °F	40 °F	
149 - 204 °F	± 6 °C	± 8 °C	22 °C	
401 - 500 °F	± 20 °F	± 25 °F	60 °F	
205 - 260 °F	± 11 °C	± 14 °C	33 °C	
501 - 550 °F	± 25 °F	± 30 °F	125 °F	
261 - 288 °F	± 14 °C	± 17 °C	69 °C	

NOTE: Differences in temperature testing procedures and equipment, between those of the manufacturer and the customer, can result in temperature variances of up to 2°F.

## ELECTRICAL RATINGS (Resistive)

**TABLE 2**

120 VAC	240 VAC	30 VDC	Cycles	Approvals
10 A	10 A	2A	100,000	
5A 120 VA	5A 120 VA			 

 and  units rated for AC operation only.  
U.L. File E18974, Guide XAPX2  
C.S.A. File LR 7378, Class 4823 02.

**TABLE 3**

## Mounting Bracket

- B1—No Bracket (Cap Only)
- B2—Bottom Oval Flange
- B6—Stud Mounting Screw

## Cap and Mounting Flange Material

- C3—Stainless Steel

## Mounting Hardware Size

- H1—No hardware (use with B1)
- H4—#6 screw for flange mounting
- H6—#6 screw for stud mounting

## Terminal Positions

- T1—Eyelet, opposed horizontal
- T2—Eyelet, opposed vertical
- T3—Eyelet, parallel horizontal
- T6—1/4" Quick Connect, opposed horizontal
- T7—1/4" Quick Connect, opposed vertical
- T10—Leads, opposed horizontal
- T11—Leads, opposed vertical
- T12—Leads, parallel horizontal
- T13—Leads, parallel vertical

## Lead Wires (specify length)

- L1—No Lead Wires
- L3—200°C TFE, 18 AWG, 300V insulation
- L4—250°C TGGT, 18 AWG, 300V insulation

## OUTLINE DIMENSIONS

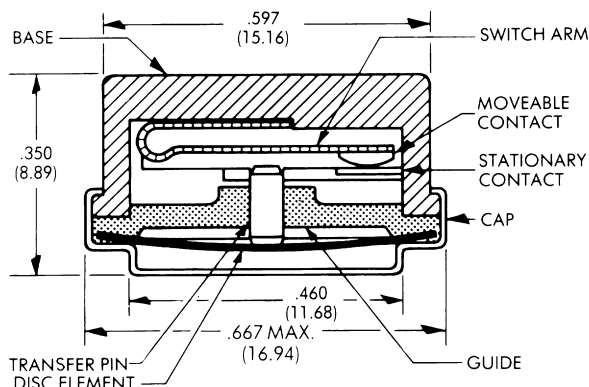

## TERMINALS AND POSITIONS

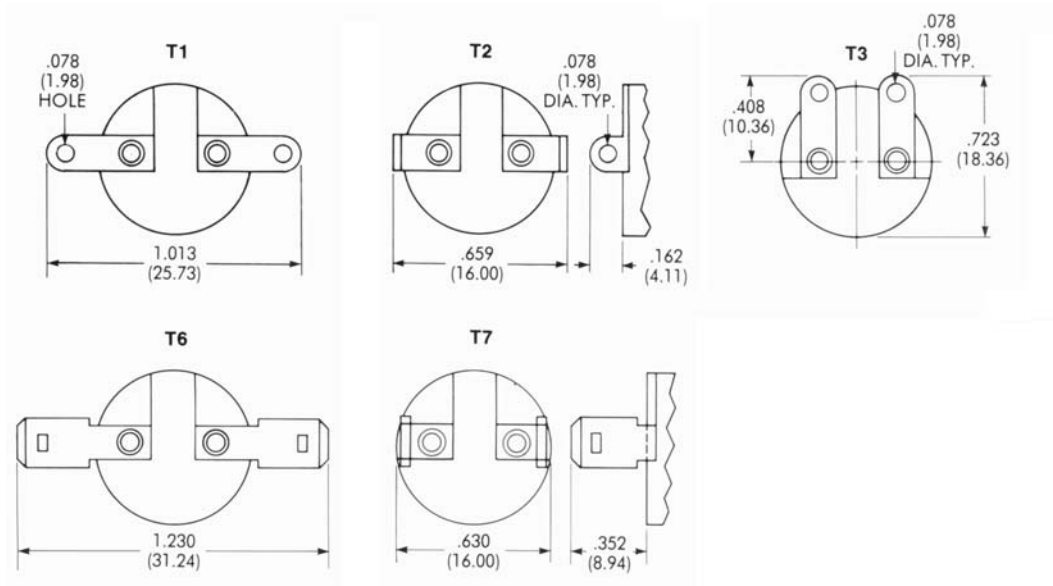

## MOUNTING BRACKETS

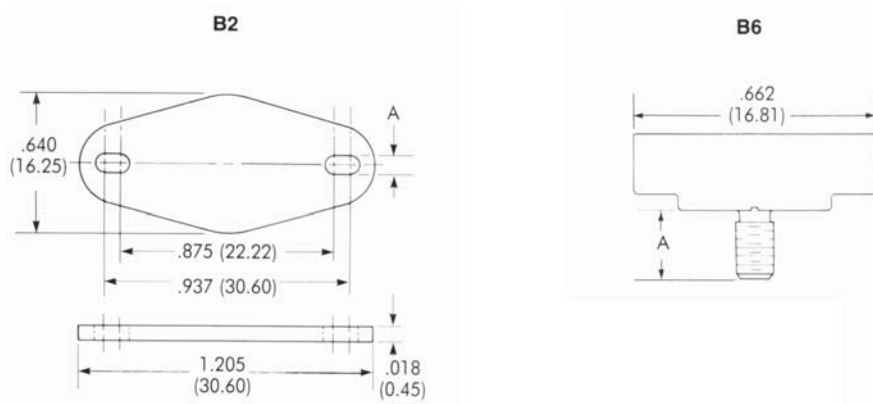

## MOUNTING HARDWARE SIZE

Hardware Size	Dim. A
H4	.143 (3.63)

Hardware Size	Dim. A
H6	6-32 x 3/8"

*Dimensions in brackets are millimeters.*

*Specifications subject to change without notice.*

---

Represented By: Ross & Pethel  
Phone: 225-273-2202 [Website](#)



400 MAIN STREET, ASHLAND, MA 01721  
TEL: (508) 881-2000 FAX: (508) 881-6729  
[www.fenwalcontrols.com](http://www.fenwalcontrols.com)

These instructions do not purport to cover all the details or variations in the equipment described, nor do they provide for every possible contingency to be met in connection with installation, operation and maintenance. All specifications are subject to change without notice. Should further information be desired or should particular problems arise which are not covered sufficiently for the purchaser's purposes, the matter should be referred to KIDDE-FENWAL, Inc., Ashland, Massachusetts.

P/N 8.11.8