

# UCJ SERIES

## INSTITUTIONAL ELECTRIC CONVECTORS

- 500 WATTS THRU 1500 WATTS OUTPUT
- CONVECTION DESIGNED FOR SAFETY

### SELECTION CHART

CATALOG NUMBER	HEATER VOLTS	WATTS (KW)	AMPS	WT. (LBS.)
UCJ400	120	400	3.3	38
UCJ408	208		1.9	
UCJ404	240		1.7	
UCJ407	277		1.4	
UCJ500	120	500	4.2	43
UCJ508	208		2.4	
UCJ504	240		2.2	
UCJ507	277		1.8	
UCJ750	120	750	6.2	53
UCJ758	208		3.6	
UCJ754	240		3.3	
UCJ757	277		2.7	
UCJ1000	208	1000	8.3	63
UCJ1008	208		4.8	
UCJ1004	240		4.4	
UCJ1007	277		3.6	
UCJ1250	120	1250	10.4	78
UCJ1258	208		6.0	
UCJ1254	240		5.4	
UCJ1257	277		4.5	
UCJ1500	120	1500	12.5	93
UCJ1508	208		7.2	
UCJ1504	240		6.5	
UCJ1507	277		5.4	
UCJ2008	208	2000	9.6	128
UCJ2004	240		8.8	
UCJ2007	277		7.2	

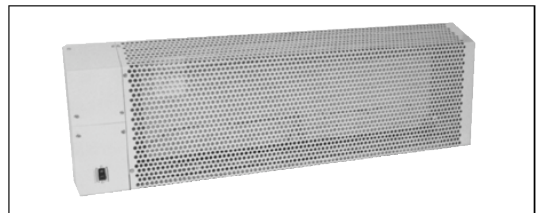

### APPLICATIONS

UCJ Series type convector is designed as an institutional unit with low operating temperatures and is U.L. listed. This is a rugged, wall mounted, tamper proof convection heater designed to provide heat in correctional or rehabilitation institutions where safety is a major concern.

### FEATURES

- 140° F maximum surface temperature in a 70° ambient means the unit is ideal for applications that require a low-operating temperature below that of most commercial convectors.
- Internal tamper proof thermostat with 55° to 100° F range allows for temperature control of the unit with a high degree of security.
- 12 gauge perforated steel, sloped top cover makes the unit rugged and resistant to any attempted vandalism.
- A built-in double pole disconnect switch that is accessible without the removal of any covers results in a convenient means of disconnecting power to the unit for servicing and cleaning.
- A durable, baked enamel finish insures that the unit will resist chipping, cracking, or rusting throughout the life of the unit.

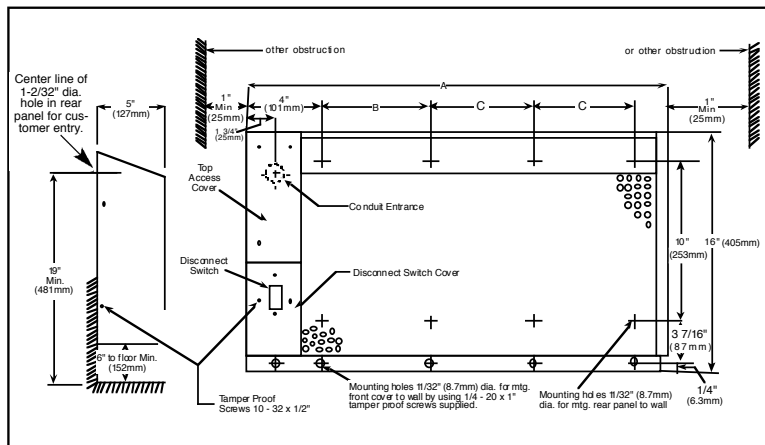

### DIMENSIONS

WATTAGE	LENGTH	HEIGHT	DEPTH
400	24"	16"	5"
500	28"	16"	5"
750	36"	16"	5"
1000	48"	16"	5"
1250	60"	16"	5"
1500	72"	16"	5"
2000	96"	16"	5"



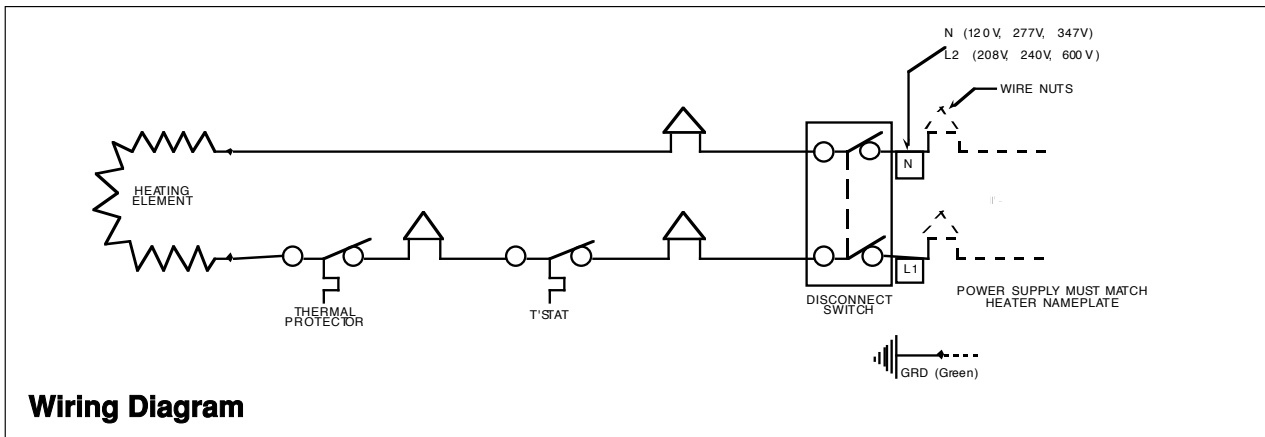

### ARCHITECTS & ENGINEER'S SPECIFICATIONS

Furnish and install where indicated on plans, electric institutional convectors suitable for continuous operation as manufactured by Berko, A Marley Engineered Products Brand, Bennettsville, SC, USA. Heaters shall be UL Listed for use in the United States and Canada.

**ENCLOSURE:** The element cover enclosure shall be fabricated from 12 ga. cold rolled steel and perforated with 0.375" diameter holes located on 0.500" centers. The open area of the element cover enclosure shall be 50%. The maximum surface temperature on the element cover enclosure shall be 140 deg. F (60 degrees C) at a 70 deg. F (21 degrees C) ambient. The control compartment covers shall also be fabricated from 12 ga. cold rolled steel. The one piece back plate shall be fabricated from 14 ga. cold rolled steel and shall mount to the wall with a minimum of four bolts.

**SIZE:** Heaters shall be 16" in height (including the 1" mounting flange on bottom of front cover) and shall be 5" in depth. It shall be available in lengths from 28" through 72".

**FINISH:** All sheet metal parts shall all be finished utilizing a 5 stage phosphatizing treatment prior to the application of a high gloss baked enamel finish. The color shall be neutral gray.

**HEATING ELEMENTS:** The electric heating element assembly shall consist of a steel sheath heating element for strength and corrosion resistance and aluminum fins pressure bonded to the sheath for fast, efficient heat transfer. The element assembly shall be centered anchored and shall float freely on each end through high temperature Noryl bushings.

**CONTROLS:** An automatic reset thermal overload protector shall run the full length of the element and shall turn the element off should overheating occur at any point along the length. The protector shall restore operation automatically when the cause of overheating is removed.

A double pole disconnect switch shall be mounted on the lower control compartment cover and shall be accessible without the removal of any covers or panels. It shall be protected on both sides by guards that are welded to the cover and extended upward, stopping above the height of the disconnect switch to protect it from damage upon impact with a foreign object.

A single pole thermostat shall be mounted in the control compartment and shall be adjustable from 55 degrees F to 100 degrees F (13 degrees C to 38 degrees C). It shall not be accessible without the removal of the upper control compartment cover.

**FASTENERS:** The element cover enclosure and control compartment covers shall be secured to the back plate with spanner head tamper resistant screws. The bottom of the element cover enclosure and the bottom of the lower control compartment cover shall be secured to the wall with spanner head tamper resistant bolts. These screws and bolts shall be provided by the heater manufacturer.

### APPLICATION LIMITATIONS AND PRECAUTIONS

**A. HAZARDOUS ATMOSPHERE** - Because the possibility of a concealed spark can exist from the built-in controls, heaters should not be used in potentially explosive atmospheres.

**B. CORROSIVE ATMOSPHERE** - The high quality finish and steel internal sheet metal parts will give excellent service under most operating conditions, including coastal salt air and industrial atmospheres. However, the finish is not intended for direct salt spray exposure in marine application or highly corrosive industrial, greenhouse, swimming pool, or chemical storage atmospheres.

**C. CLEANLINESS** - Although specifically designed for mounting below window areas, heaters can be installed on plaster, wood paneled, metal, masonry, or composition wall surfaces with reasonable expectation of clean wall operation. Should some soiling occur, after a period of years, smooth walls may be cleaned with standard maintenance materials.

**D. COMFORT** - Optimum room comfort results when heater is mounted just below the window sill, since window cold down draft is eliminated and maximum convection air distribution without stratification is maintained throughout the room. Because of the tendency for warm air to stratify, installing heaters close to the ceiling is not recommended. If it should be necessary, at least 18" clearance above the air discharge must be maintained. Bottom of heaters should be mounted no less than 6" from floor.

**E. AIR THROW** - Since heaters provide only natural convection air throw, they are not recommended for combating cold outside air blasts through high traffic, main entryways and vestibules. Heaters will maintain satisfactory comfort conditions in low traffic, side entryways and vestibules, but for most entryways, faster response fan driven heaters would be preferred.

**F. CURTAINS** - Curtains, drapes, or blinds — should clear the top of the heater by at least six inches. Never permit draperies to completely cover the unit. Furniture — should be placed so it does not touch the heater and so it does not completely block the air vents. Allow at least 4" free space between furniture and the heaters.

**G. RECESS MOUNTING** - UL labeled for free standing wall surface mounting only. Not recommended for mounting behind built-in book shelves, storage cabinets, window seats, etc.

**H. WALL COVERINGS** - Due to variations in vinyl compositions, when installing on vinyl wall coverings or under vinyl window dressings, prior to setting specifications, consult factory for installation recommendations.



470 Beauty Spot Rd., E  
Bennettsville, SC 29512 USA