

FDI SERIES FLOOR DROP-IN HEATER

- HEAVY DUTY GRILLE
- OVERHEAT THERMAL PROTECTOR
- SANDALWOOD BAKED ENAMEL GRILLE FINISH

- PUSH-ON TAB WIRE TERMINALS
- QUIET OPERATION
- VERSATILE, UNIVERSAL SIZE DRAFT BARRIER HEATER

APPLICATIONS

The FDI Drop-In Floor Heater, with its complete line of accessories and controls, can be used in virtually any location. Featuring a flow pattern of warm air five feet wide and four feet above the floor, the FDI is perfect for large window areas, entry ways, open stair wells as well as entire room areas. Heavy-duty grille can take almost any type of abuse.

DIMENSIONS

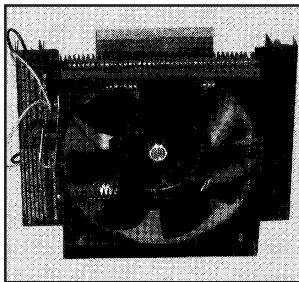
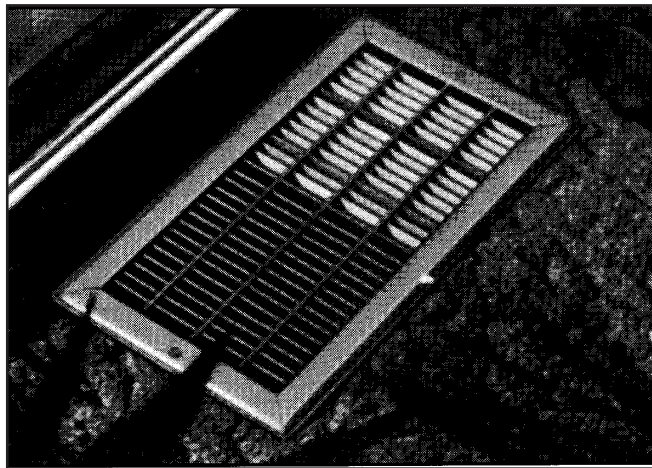
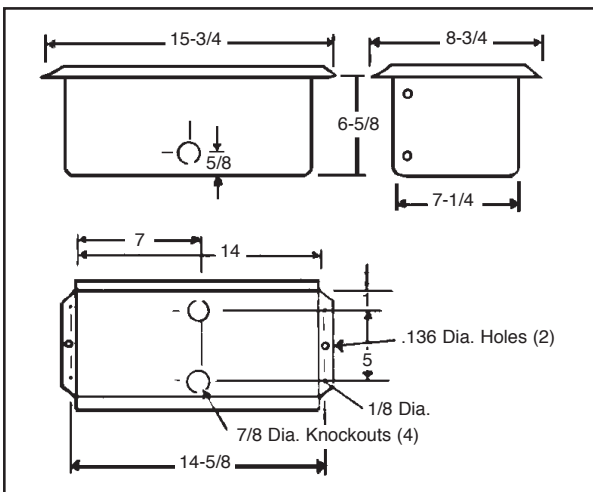

FEATURES

DUAL WATTAGE

Both the FDI1500 and FDI1504 are adaptable from 1500W to 750W. Additionally, the BFDI1504 may be operated at 208 volts for an output of 1125W or 563W.

QUICK, SIMPLE INSTALLATION

Mounts between floor joists in either direction. Rough-in separate housing... then insert "plug-in" type heater element and fan assembly.

HEAVY-DUTY CAPABILITIES

Sandalwood baked enamel finish and heavy-gauge steel housing with baked enamel finish make this unit practically indestructible.

INTEGRAL THERMOSTAT ACCESSORY KIT

Easily installed in heater and adjustable through grille (when heater is installed for overall room heating, use a customer supplied wall thermostat for individual heater temperature control).

OVER TEMPERATURE PROTECTION

Each unit comes equipped with an automatic over temperature protector that guards against overheating. Also standard is a thermal fuse provides a second level of over temperature protection.

SPECIFICATIONS

*Volts	Watts	BTU/Hr.	Amps	Cat. No.
120	1500	5120	12.5	FDI1500
	750	2560	6.3	
208	1125	3840	5.4	FDI1504
	562	1920	2.7	
240	1500	5120	6.3	FDI-TSP
	750	2560	3.1	
Integral Thermostat Kit				FDI-TSP

* 60Hz: single phase

Limitations: Do not install in bathroom or other areas where water may enter heater unit. Do not locate where air flow may be obstructed (under drapes, behind doors, etc.). Keep small side at least 3' from side walls.



FILE #E21609

Architect's and Engineer's Specifications*

Furnish and install, where indicated on plans, FDI electric fan forced air heater suitable for installing in the floor as manufactured by Berko, a Marley Engineered Products Brand, Bennettsville, SC. Heaters shall be UL Listed c-UL Listed.

ENCLOSURE: The heater shall be fabricated of 20-gauge cold rolled steel, completely welded, then painted by a baked enamel finish. The louvered grille and grille frame shall be finished in sandalwood color by a baked enamel painting process.

HEATING ELEMENT: The heating element shall be guaranteed for five years and shall be non-glowing design consisting of a special 80/20 NiChrome resistance wire enclosed in a steel sheath to which steel fins are brazed.

MOTOR AND CONTROLS: The fan motor shall be impedance protected and permanently lubricated. An optional single pole thermostat accessory shall be specified where the unit will not utilize wall thermostat. The over-temperature protector shall be bi-metallic, snap-action type designed to shut off heater in the event of overheating. A thermal fuse shall provide secondary thermal cut-out for added safety.

*Berko reserves the right to change specifications without prior notice.

Distributed By:



A Marley Engineered Products Brand
470 Beauty Spot Road East
Bennettsville, SC 29512

Printed in U.S.A.