

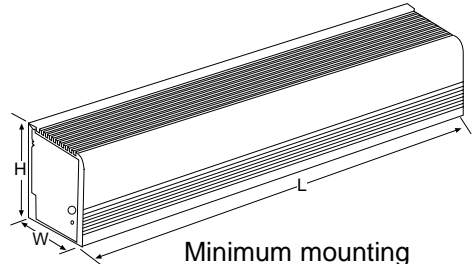

# ASL3 & ASL5 Architectural Sill-Height Convection Heaters

Table A - ASL3 & ASL5 (one element)

Catalog Number	Length "L"	Watts per ft.	Total Watts	Amperage			
				120V	208V	240V	277V
02100	28" (711mm)	100	200	1.7	1.0	0.8	--
02125		125	250	2.1	1.2	1.0	0.9
02150		150	300	2.5	1.4	1.3	1.1
02188		188	376	3.1	1.8	1.6	1.4
02250		250	500	4.2	2.4	2.1	1.8
03100	3' (914mm)	100	300	2.5	1.4	1.3	1.1
03125		125	375	3.1	1.8	1.6	1.4
03150		150	450	3.8	2.2	1.9	1.6
03188		188	564	4.7	2.7	2.4	2.0
03250		250	750	6.3	3.6	3.1	2.7
04100	4' (1219mm)	100	400	3.3	1.9	1.7	1.4
04125		125	500	4.2	2.4	2.1	1.8
04150		150	600	5.0	2.9	2.5	2.2
04188		188	752	6.3	3.6	3.1	2.7
04250		250	1000	8.3	4.8	4.2	3.6
05100	5' (1524mm)	100	500	4.2	2.4	2.1	1.8
05125		125	625	5.2	3.0	2.6	2.3
05150		150	750	6.3	3.6	3.1	2.7
05188		188	940	7.8	4.5	3.9	3.4
05250		250	1250	10.4	6.0	5.2	4.5
06100	6' (1829mm)	100	600	5.0	2.9	2.5	2.2
06125		125	750	6.3	3.6	3.1	2.7
06150		150	900	7.5	4.3	3.8	3.2
06188		188	1128	9.4	5.4	4.7	4.1
06250		250	1500	12.5	7.2	6.3	5.4
07100	7' (2134mm)	100	700	--	3.4	2.9	2.5
07125		125	875	--	4.2	3.6	3.2
07150		150	1050	--	5.0	4.4	3.8
07188		188	1316	--	6.3	5.5	4.8
07250		250	1750	--	8.4	7.3	6.3
08100	8' (2438mm)	100	800	--	3.8	3.3	2.9
08125		125	1000	--	4.8	4.2	3.6
08150		150	1200	--	5.8	5.0	4.3
08188		188	1504	--	7.2	6.3	5.4
08250		250	2000	--	9.6	8.3	7.2
09100	9' (2743mm)	100	900	--	4.3	3.8	3.2
09125		125	1125	--	5.4	4.7	4.1
09150		150	1350	--	6.5	5.6	4.9
09188		188	1692	--	8.1	7.1	6.1
09250		250	2250	--	10.8	9.4	8.1
10100	10' (3048mm)	100	1000	--	4.8	4.2	3.6
10125		125	1250	--	6.0	5.2	4.5
10150		150	1500	--	7.2	6.3	5.4
10188		188	1880	--	9.0	7.8	6.8
10250		250	2500	--	12.0	10.4	9.0



## Dimensions

Type	Height	Width	Length
ASL3	6"	3-5/8"	28" to 15'
	152mm	92mm	711mm to 4572mm
ASL5	7"	5-3/8"	28" to 12'
	178mm	136mm	711mm to 3658mm

## Minimum mounting height above floor

ASL3 & ASL5 front inlet	0"
ASL3 & ASL5 bottom inlet (100 W/ft.-250 W/ft.)	1-3/4" (44mm)
ASL5 Bottom Inlet (375 W/ft.-750 W/ft.)	3" (76mm)

## ASL5 (two and three element)

Catalog Number	Length "L"	Watts per ft.	Total Watts	Amperage				
				208V		240V		277V
				1 Ph	3 Ph	1 Ph	3 Ph	1 Ph
02375	28" (711mm)	375	750	3.6	-	3.1	-	2.7
02500		500	1000	4.8	-	4.2	-	3.6
02600		600	1200	5.8	3.3	5.0	2.9	4.3
02750*		750	1500	7.2	4.2	6.3	3.6	5.4
03375	3' (914mm)	375	1125	5.4	-	4.7	-	4.1
03500		500	1500	7.2	-	6.3	-	5.4
03600		600	1800	8.7	5.0	7.5	4.3	6.5
03750*		750	2250	10.8	6.3	9.4	5.4	8.1
04375	4' (1219mm)	375	1500	7.2	-	6.3	-	5.4
04500		500	2000	9.6	-	8.3	-	7.2
04600		600	2400	11.5	6.7	10.0	5.8	8.7
04750*		750	3000	14.4	8.3	12.5	7.2	10.8
05375	5' (1524mm)	375	1875	9.0	-	7.8	-	6.8
05500		500	2500	12.0	-	10.4	-	9.0
05600		600	3000	14.4	8.3	12.5	7.2	10.8
05750*		750	3750	18.0	10.4	15.6	9.0	13.5
06375	6' (1829mm)	375	2250	10.8	-	9.4	-	8.1
06500		500	3000	14.4	-	12.5	-	10.8
06600		600	3600	17.3	10.0	15.0	8.7	13.0
06750*		750	4500	21.6	12.5	18.8	10.8	16.2
07375	7' (2134mm)	375	2625	12.6	-	10.9	-	9.5
07500		500	3500	16.8	-	14.6	-	12.6
07600		600	4200	20.2	11.7	17.5	10.1	15.2
07750*		750	5250	25.2	14.6	21.9	12.6	19.0
08375	8' (2438mm)	375	3000	14.4	-	12.5	-	10.8
08500		500	4000	19.2	-	16.7	-	14.4
08600		600	4800	23.1	13.3	20.0	11.6	17.3
08750*		750	6000	28.8	16.7	25.0	14.5	21.7
09375	9' (2743mm)	375	3375	16.2	-	14.1	-	12.2
09500		500	4500	21.6	-	18.8	-	16.2
09600		600	5400	26.0	15.0	22.5	13.0	19.5
09750*		750	6750	32.5	18.8	28.1	16.3	24.4
10375	10' (3048mm)	375	3750	18.0	-	15.6	-	13.5
10500		500	5000	24.0	-	20.8	-	18.1
10600		600	6000	28.8	16.7	25.0	14.5	21.7
10750*		750	7500	36.1	20.8	31.3	18.1	27.1

\*Bottom inlet only

## Installation & Maintenance Instructions



**Read Carefully** - These instructions are written to help you prevent difficulties that might arise during installation of ASL3 and ASL5 Series Sill-Height Heaters. Studying these instructions first may save you considerable time and money later. ASL3 and ASL5 series Sill-Height Heaters are designed to easy and economical installation. Follow these instructions to keep your installation time to a minimum.

- Hazard of electric shock** - More than one disconnect switch may be required to de-energize heaters. Disconnect all sources of power to all heat decks at main service panel before wiring or servicing this heater. All wiring must be in accordance with National and local electrical codes and the entire heater installation must be grounded as a precaution against possible electrical shock.
- Do not install the heater in an explosive or corrosive environment, or upside down or where water is present.

- Do not locate the heater below an electrical convenience receptacle.
- High temperature** - Keep electrical cords, furniture, draperies or any other blocking material at least four inches away from top or front of heater.
- Do not install heaters against paperboard or low-density fiberboard surfaces.
- Due to variations in vinyl compositions and their potential to discolor, the use of stand off brackets (SO1A and SO2A) and or specifying a lower watt density unit may be required when installing on vinyl wall coverings or under vinyl window dressings.
- Check the supply voltage to make sure it is the same as indicated on the heater nameplate before energizing.
- Discard packing pads before heater is used.
- To reduce the risk of fire, do not store or use gasoline or other flammable vapors or liquids in the vicinity of this heater.

## Accessories

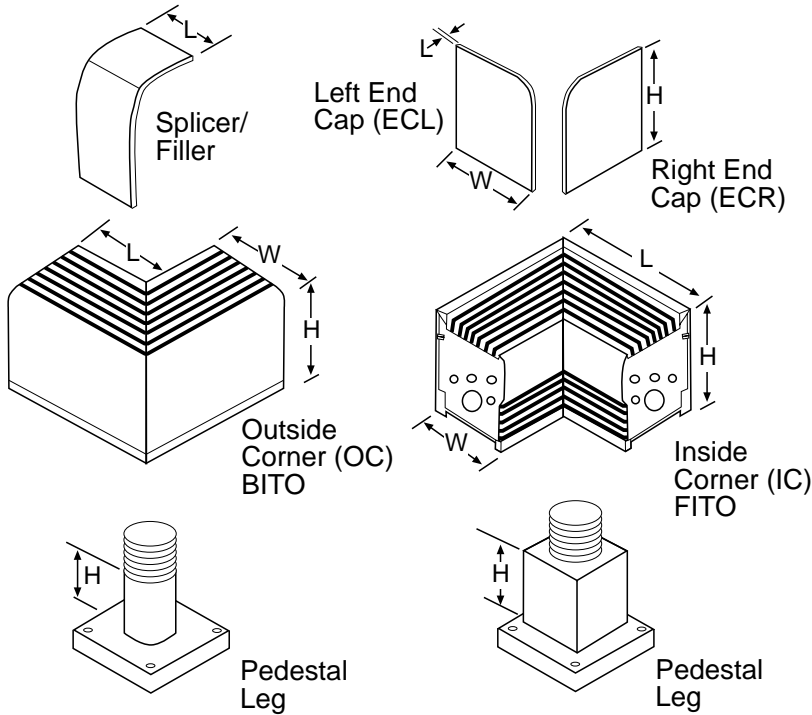

Catalog No.	Length* (mm)	Height (mm)	Width (mm)
ASL3-IC**	8-1/2"(216)	6"(152)	3-5/8"(92)
ASL3-OC**	5"(127)	6"(152)	3-5/8"(92)
ASL3-135IC**	8-1/2"(216)	6"(152)	3-5/8"(92)
ASL3135OC**	5"(127)	6"(152)	3-5/8"(92)
ASL3-ECL/ASL3-ECLS	1/8"(3)	6"(152)	3-5/8"(92)
ASL3-ECR/ASL3-ECRS	1/8"(3)	6"(152)	3-5/8"(92)
ASL3-SP	0-3/8"(0-10)	6"(152)	3-5/8"(92)
ASL3-FL3	0-3"(0-76)	6"(152)	3-5/8"(92)
ASL3-FL6	3-6"(76-152)		
ASL3-FL9	6-9"(152-229)		
ASL3-FL12	9-12"(229-305)		
ASL3-FL18	15-18"(381-457)		
ASL5-IC**	10"(254)	7"(178)	5-3/8"(137)
ASL5-OC**	5"(127)	7"(178)	5-3/8"(137)
ASL5-135IC**	10"(254)	7"(178)	5-3/8"(137)
ASL5135OC**	5"(127)	7"(178)	5-3/8"(137)
ASL5-ECL/ASL5-ECLS	1/8"(3)	7"(178)	5-3/8"(137)
ASL5-ECR/ASL5-ECRS	1/8"(3)	7"(178)	5-3/8"(137)
ASL5-SP	0-3/8"(0-10)	7"(178)	5-3/8"(137)
ASL5-FL3	0-3"(0-76)	7"(178)	5-3/8"(137)
ASL5-FL6	3-6"(76-152)		
ASL5-FL9	6-9"(152-229)		
ASL5-FL12	9-12"(229-305)		
ASL5-FL18	15-18"(381-457)		
PK3S	0	2-7/8"(73)	
PK3A	0	2-7/8"(73)	
PK5S	0	4-1/8"(105)	
PK5A	0	4-1/8"(105)	

\* "L" Dimension is the additional length the accessory adds to the total installation length.

\*\* Add suffix "B" for Bottom Inlet; "F" for front inlet.

## Installation Instructions

### Step 1 - Rough in Wire

1. Run branch circuit of proper voltage and wire size to location of left or right junction box as indicated on heater wiring diagram. Basic heaters are prewired and can be connected to branch circuit at either end. Heaters with controls are prewired for connection to branch circuit at one end only (refer to heater wiring diagram). However, heater can be wired from opposite end by running wires through heater wireway. See Fig. 2 for knockout locations.
2. If it is necessary to run wires through the heater wireway, use Table B to size the field installed wiring.
3. The factory installed wires in the heater wireway can be loaded up to 45 amps. Refer to Table C for maximum length of heater run when the heaters are connected in parallel.



### WARNING

IF THE FACTORY INSTALLED WIRES IN THE WIREWAY ARE USED TO CONNECT THE BUILT-IN CONTROL, LIMIT THE MAXIMUM CURRENT TO THE FOLLOWING VALUES.

<b>Disconnect Switch:</b>	20 amps @ 120-277 VAC
<b>Thermostat:</b>	25 amps @ 120-240 VAC 22 amps @ 277 VAC
<b>Transformer Relay:</b>	25 amps @ 120-240 VAC 22 amps @ 277 VAC
<b>Power Relay Pneumatic/Electric Switch</b>	25 amps @ 120-277 VAC

Table B. Sizing Field Installed Wiring

Copper wire size 90° C	Max. No. wire that may be installed in wireway	Maximum Allowable Current		
		Up to 3 conductors	4 to 6 conductors	7 to 9 conductors
No. 12 AWG	9	11.5 Amps	9.3 Amps	8.1 Amps
No. 10 AWG	8	17.4 Amps	14.0 Amps	12.1 Amps
No. 8 AWG	4	24.0 Amps	21.0 Amps	-

Table C. Maximum Length of Heater Run

Watts/Ft. of Heaters	Max. allowable length of heater run in feet (meters)					
	120V		208V		240V	
	1 Ph	3 Ph	1 Ph	3 Ph	1 Ph	3 Ph
100	54 (16)	93 (28)	-	108 (33)	-	124 (38)
125	43 (13)	74 (23)	-	86 (26)	-	99 (30)
150	36 (11)	62 (19)	-	72 (22)	-	83 (25)
188	28 (9)	49 (15)	-	57 (17)	-	66 (20)
250	21 (6)	37 (11)	-	43 (13)	-	49 (15)
375	-	34 (7)	-	28 (9)	-	33 (10)
500	-	18 (5)	-	21 (6)	-	24 (7)
600	-	15 (5)	27 (8)	18 (5)	31 (9)	20 (6)
750	-	12 (4)	21 (6)	14 (4)	24 (7)	16 (5)

Note: For mix of watt densities, calculate amp draw. Do not exceed 45 amps.

4. Standard 90° C wiring must be used in junction boxes, wireways, blank sections, filler sections and corner sections.

### Step 2 - Room Layout

Refer to heating plans for exact room arrangement of heaters (with or without thermostats and/or relays and/or switches and accessories).

Check the heater section dimensions and the additional wall length required for filler sections or blank sections before starting wall-to-wall type installation. Be certain all heaters and accessories needed are at hand and are of correct finish.

### Step 3 - Mounting Height

**NOTE: Up to 3/4" thick floor covering, such as carpets, tiles, linoleum, etc., may be installed around and under the heater without adversely affecting the performance of the heaters.**

At correct height, draw a pencil line on the wall, level and/or parallel with the window sill. Minimum mount heights above the floor shall be as follows.

Watts per foot of length	Minimum mounting height above floor	
	Bottom inlet	Front inlet
100, 125, 150, 188 and 250	1-3/4" (44 mm)	0" (0 mm)
375, 500, 600, and 750*	3" (76 mm)	0" (0 mm)

\* Bottom inlet only

### Step 4 - Installation (single unit)

**NOTE: For ease of installation, it is important that the sequence of operation indicated below be followed in order. For heaters with more than one heat deck, heat decks may be**

wired in parallel or each heat deck may be supplied by separate circuit. See heater nameplate for current load for each heat deck.

1. Remove unit from carton and discard external pads and plastic wrap.
2. Remove front cover by laying the heater on its back and inserting a putty knife (or other thin, wide blade tool, 1" [25mm] wide minimum.) approximately 6" (152mm) from the end of the heater and prying up as shown in Fig.1. This will spring the snap lock closure open. Repeat as required down the length of the heater until the front cover completely disengages from the heater back.

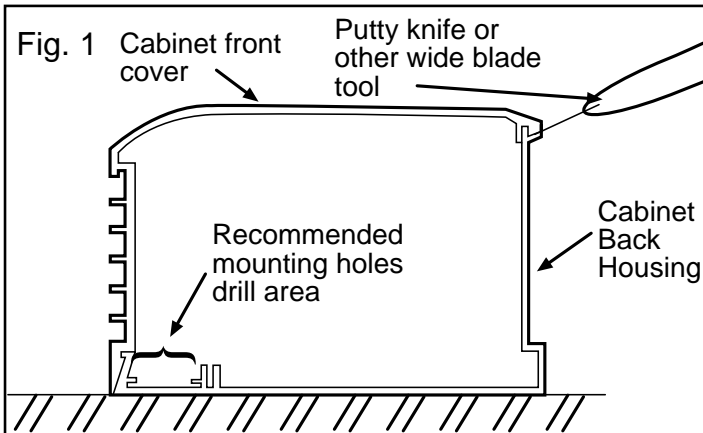

**WARNING**  
DO NOT USE SCREWDRIVER TO SPRING OPEN THE FRONT AND BACK OF THE HEATER. USE OF A SCREWDRIVER WILL RESULT IN DAMAGE TO BOTH THE FRONT AND BACK EXTRUSIONS.

3. Remove appropriate electrical knockouts from either junction box. See Fig. 2 for location of knockouts. If heater is to be pedestal mounted, consult pedestal kit installation instructions.

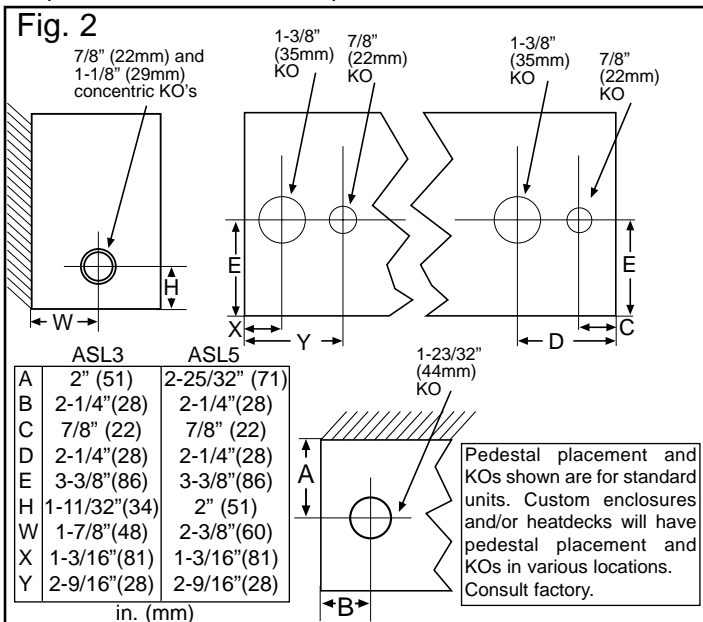

4. Drill the required size mounting holes in the heater housing (See Fig. 1 for recommended mounting hole location.)

**WARNING**  
USE CARE WHEN DRILLING MOUNTING HOLES TO AVOID DAMAGING INTERNAL HEATER COMPONENTS SUCH AS THE CAPILLARY TUBE OR ELEMENT FINNS. ALWAYS DRILL HOLES FROM THE INSIDE OF THE BACK HOUSING TOWARDS OUTSIDE.

5. Hold heater housing against the wall to check for evenness of wall. Do not draw heater against an uneven wall surface. If an uneven wall is encountered, use shims to keep the heater housing straight.
6. Run proper size branch circuit to the junction box through the selected knockout.
7. Mount the heater on the wall using screws, bolts or anchors (by installer) to suit the wall construction.
8. Tighten mounting screw and back off 1/2 turn to allow for expansion and contraction of the heater.
9. Following the wiring diagram secured to the heater, make electrical connections. Ground the heater using the ground screw provided. See Fig. 3.
10. Replace front cover by latching the bottom front edge of the front cover over the bottom front edge of the back and pushing the cover straight back to latch the top rear edge of the back with the top rear edge of the front cover. See Fig. 4.

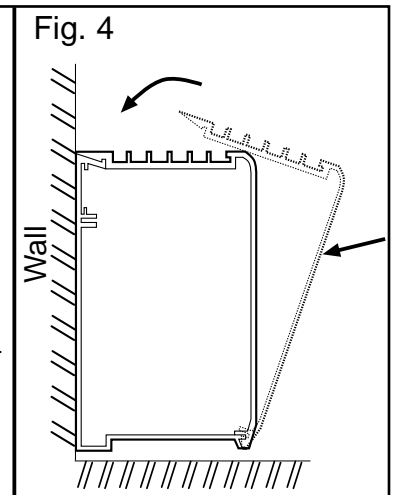
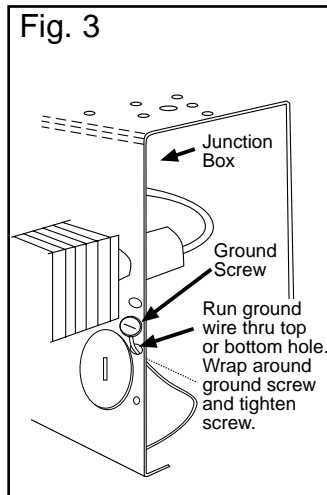

**WARNING**  
FRONT COVER MUST BE SECURELY FASTENED TO THE BACK OF THE HEATER BEFORE THE HEATER IS ENERGIZED. CHECK THE UNIT TO CONFIRM THE FRONT COVER IS SECURELY FASTENED TO THE BACK ALL ALONG THE LENGTH OF THE UNIT.

### Step 5 - Installation (Multiple Wall-to-Wall Units)

**NOTE:** For ease of installation, it is important that the sequence of operations indicated below be followed in order.

1. Repeat Steps 1 & 2 from Single Unit Installation.
2. Refer to wiring diagram for power supply entry and remove appropriate electrical knockout (Fig. 2) from the heater in which power supply connections are to be made. The power supply may be brought into the end of one heater and the remaining heaters may be connected in parallel using the wireway. Use Table B to size the field installed wiring in the wireway or use Table C to determine the maximum length or heater run possible using the factory installed wire in the heater wireway. If units are to be pedestal mounted, consult pedestal kit installation instructions.
3. If filler sections, inside corners, outside corners, splice kits or end caps are to be used, consult accessory installation instructions.

**NOTE:** If a heater has a disconnect switch and/or thermostat and is to have a filler section at the left end, the filler must not cover the access to those controls.

4. If the run of the heaters includes an inside corner or an outside corner, mount corner to wall (see accessory installation instructions packed with corners), then mount heater.

- Drill the required size mounting holes in all the heater housings. (See Fig. 1 for recommended mounting hole location.)



## WARNING

USE CARE WHEN DRILLING MOUNTING HOLES TO AVOID DAMAGING INTERNAL HEATER COMPONENTS SUCH AS THE CAPILLARY TUBE OR ELEMENT FINNS. ALWAYS DRILL HOLES FROM THE INSIDE OF THE BACK HOUSING TOWARD OUTSIDE.

- Hold heater housings against wall to check for evenness of the wall. Do not draw the heaters against an uneven wall surface. If an uneven wall is encountered, use shims to keep the heater housing straight.
- Run proper size branch circuit to the junction box through the selected knockout.
- Mount the heaters on the wall using screws, bolts or anchors (by installer) which suit the wall construction. Alignment tabs can be inserted in adjoining back housings to assure even alignment. See Fig. 5 for details.
- Following the wiring diagram secured to the heater, make the electrical connections. Refer to Fig. 7 to connect the other heaters in parallel. Grounding of the other heaters is accomplished by connecting a jumper wire (not supplied) between the two adjacent heaters.

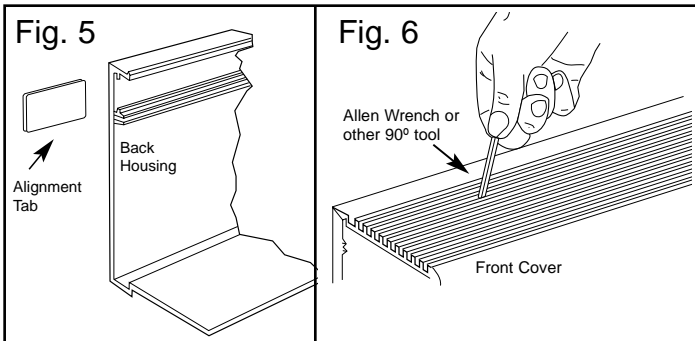

- Replace front covers following Step 10, Single Unit Installation (See Fig. 4.)

## Blank and Control Sections

- Blank sections, if any, are installed in the same manner as the heaters.
- Control sections, if any, are installed in the same manner as the heaters. Refer to wiring diagrams on control sections for connecting the wiring to the heaters.

## Operations

If the heaters are equipped with built-in thermostats, adjust the shaft to the mid-range and let the heaters run a few hours. If the room temperature is too hot, rotate the shaft counterclockwise; if too cool, rotate the shaft clockwise until a comfortable temperature is obtained. Let room temperature stabilize after each setting change.

**NOTE: The thermostat adjustment shaft and the disconnect switch are accessible through the grille opening at the left end of the heater.**

## Front Cover Removal

To remove the front cover for servicing, disengage the top rear snap-lock first. Use an "L" shaped tool, such as an Allen Wrench, to lift up under the webs between the back row of slots (See Fig. 6). Start at either end and lift up on the front cover until the tension in the cover holds the cabinet apart. Continue moving along the length of the heater until the cover comes off.

### How to order repair parts

In order to obtain any needed repair or replacement parts, warranty service or technical information, please contact Marley Engineered Products Service Center, 470 Beauty Spot Road, Bennettsville, SC 29512 or call toll-free 1-800-642-HEAT.

## Typical Wiring of Multiple Heaters (without controls)

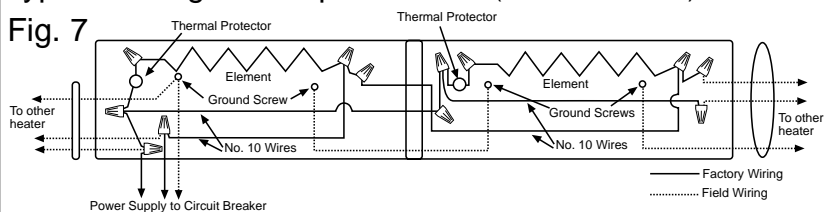

**Marley**  
Engineered Products

SPX Corporation  
470 Beauty Spot Rd. East  
Bennettsville, SC 29512 USA

## LIMITED WARRANTY

All products manufactured by Marley Engineered Products are warranted against defects in workmanship and materials for one year from date of installation, except heating elements which are warranted against defects in workmanship and materials for five years from date of installation. This warranty does not apply to damage from accident, misuse, or alteration; nor where the connected voltage is more than 5% above the nameplate voltage; nor to equipment improperly installed or wired or maintained in violation of the product's installation instructions. All claims for warranty work must be accompanied by proof of the date of installation.

The customer shall be responsible for all costs incurred in the removal or reinstallation of products, including labor costs, and shipping costs incurred to return products to Marley Engineered Products Service Center. Within the limitations of this warranty, inoperative units should be returned to the nearest Marley authorized service center or the Marley Engineered Products Service Center, and we will repair or replace, at our option, at no charge to you with return freight paid by Marley. It is agreed that such repair or replacement is the exclusive remedy available from Marley Engineered Products.

THE ABOVE WARRANTIES ARE IN LIEU OF ALL OTHER WARRANTIES EXPRESSED OR IMPLIED AND ALL IMPLIED WARRANTIES OF MERCHANTABILITY AND FITNESS FOR A PARTICULAR PURPOSE WHICH EXCEED THE AFORESAID EXPRESSED WARRANTIES ARE HEREBY DISCLAIMED AND EXCLUDED FROM THIS AGREEMENT. MARLEY ENGINEERED PRODUCTS SHALL NOT BE LIABLE FOR CONSEQUENTIAL DAMAGES ARISING WITH RESPECT TO THE PRODUCT, WHETHER BASED UPON NEGLIGENCE, TORT, STRICT LIABILITY, OR CONTRACT.

Some states do not allow the exclusion or limitation of incidental or consequential damages, so the above exclusion or limitation may not apply to you. This warranty gives you specific legal rights, and you may also have other rights which vary from state to state.

For the address of your nearest authorized service center, contact Marley Engineered Products in Bennettsville, SC, at 1-800-642-4328. Merchandise returned to the factory must be accompanied by a return authorization and service identification tag, both available from Marley Engineered Products. When requesting return authorization, include all catalog numbers shown on the products.